

# DM 250

# D.C.E.M. Brake

## Introduction

DC Electro-magnetic shoe brakes are actuated by an energy stored in the compression spring and is released by a DC electromagnet. Thus, the brake is fail-safe and is normally ON (applied). The DC magnet coil, when energized releases the brake.

This series of brakes are characterized by robust construction and design. These are specially suited for Steel Mills, Hoists and Elevators.

## Brake Selection

The braking torque is generally decided as a percentage of rated torque of the drive motor. Rated torque of motor is given by

$$T = 716.2 \times (\text{HP} / \text{RPM}) \text{ kg-m.}$$

OR

$$M = 0.974 \times (\text{KW} / \text{RPM}) \text{ N-m}$$

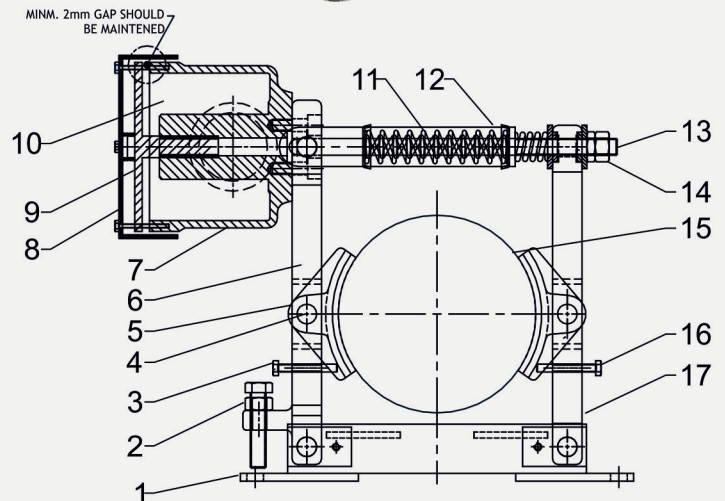
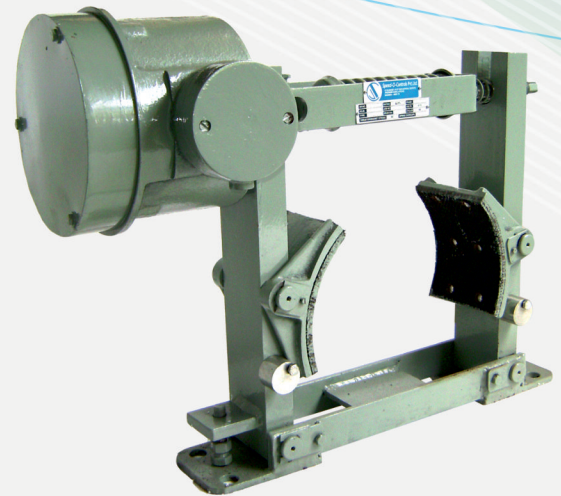
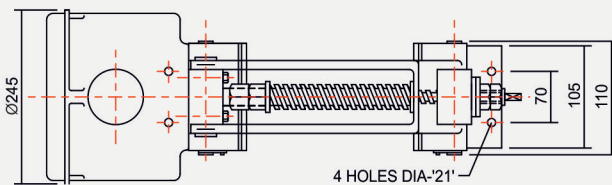
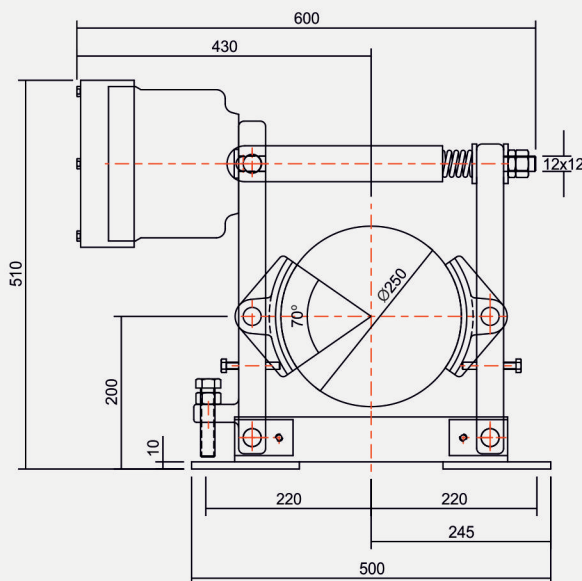

- (01) Base
- (02) Stopper Screw
- (03) Main Arm Shoe adj. screw
- (04) Shoe hinge pin
- (05) Brake Shoe
- (06) Main Arm
- (07) Magnet Housing
- (08) Housing Cover
- (09) Armature
- (10) Magnet Coil
- (11) Compression Spring
- (12) Fork
- (13) Tie Rod
- (14) Tie Rod Nuts
- (15) Brake Drum
- (16) Side Arm Shoe adj. screw
- (17) Side Arm

Brake Model	Item Code	Brake Drum Dimension (mm)	Braking Torque (kg-m)	Supply Volts At 50 Hz (V)	* Mass (kg)
DM-250	100900050001	250	35	415	70

Supply Voltage 380/480/550/690V available on request



## Speed-O-Controls Pvt. Ltd.

H. O. Unit - I : C-15/16, Nand Jyot Industrial Estate, Andheri-Kurla Road, Mumbai - 400072,  
 Tel : (022) 42469700-30, 28518512-3-4,  
 Fax : (022) 42469797/ 28518516,  
 E-mail : sales@socgroup.in

Unit - II: Plot No. 4912, G. I. D. C., Phase IV, Vatva, Ahmedabad - 382445  
 Tel.: (079) 40083201/2/3/4,  
 Fax : (079) 25841056,  
 E-mail : sales.amd@socgroup.in

Visit us at :  
[www.speedocontrols.com](http://www.speedocontrols.com)  
[www.socremote.com](http://www.socremote.com)