

DM 800

D.C.E.M. Brakes

Introduction

DC Electro-magnetic shoe brakes are actuated by an energy stored in the compression spring and is released by a DC electromagnet. Thus, the brake is fail-safe and is normally ON (applied). The DC magnet coil, when energized releases the brake.

This series of brakes are characterized by robust construction and design. These are specially suited for Steel Mills, Hoists and Elevators.

Brake Selection

The braking torque is generally decided as a percentage of rated torque of the drive motor.

Rated torque of motor is given by

$$T = 716.2 \times (\text{HP} / \text{RPM}) \text{ kg-m.}$$

OR

$$M = 0.974 \times (\text{KW} / \text{RPM}) \text{ N-m}$$

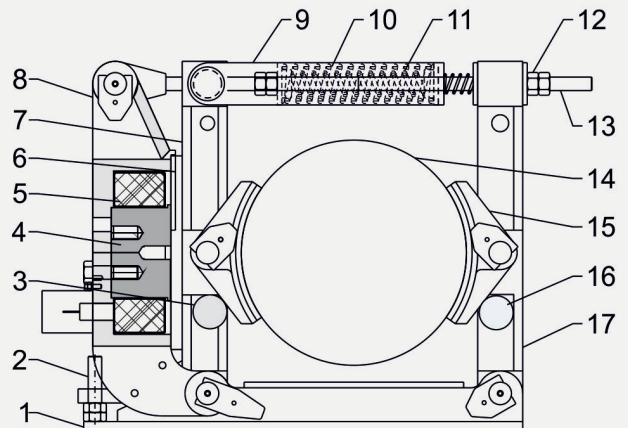
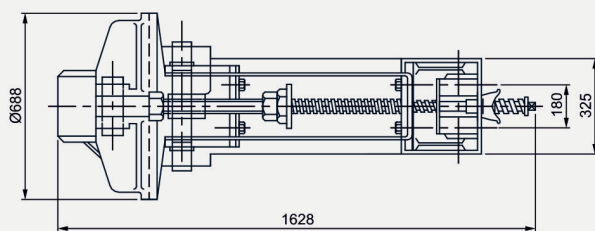
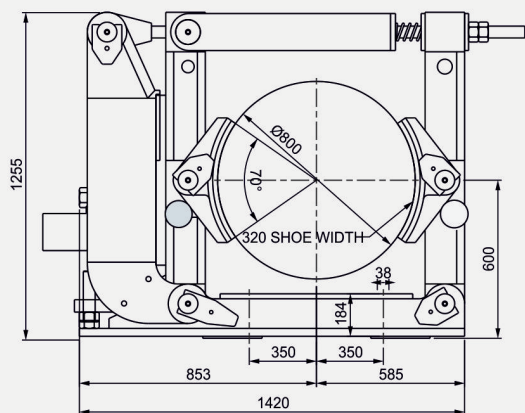
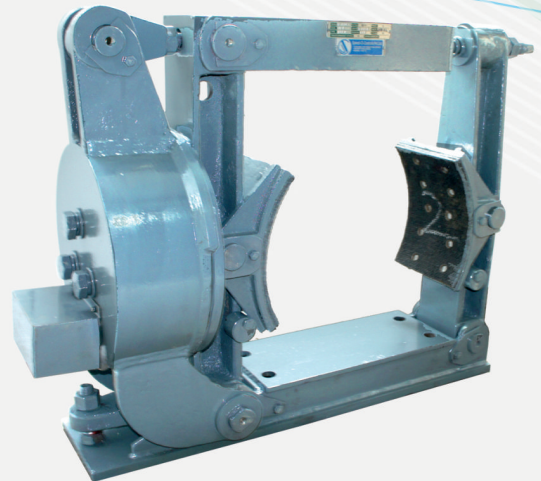

- (01) Base
- (02) Stopper Screw
- (03) Main Arm Shoe adj. screw
- (04) Shoe hinge pin
- (05) Magnet Coil
- (06) Armature
- (07) Main Arm
- (08) Magnet Housing
- (09) Fork
- (10) Compression Spring-1
- (11) Compression Spring-2
- (12) Tie Rod Nuts
- (13) Tie Rod
- (14) Brake Drum
- (15) Brake Shoe
- (16) Side Arm Shoe adj. screw
- (17) Side Arm

Brake Model	Item code	Brake Drum	Braking Torque	Supply Volts At 50Hz	*Mass
		(mm)	(kg-m)	(V)	(kg.)
DM-800	100900120001	800	910	415	1360

Supply Voltage 380/480/550/690V available on request



Speed-O-Controls Pvt. Ltd.

H. O. Unit - I : C-15/16, Nand Jyot Industrial Estate,
Andheri-Kurla Road, Mumbai - 400072,
Tel : (022) 42469700-30, 28518512-3-4,
Fax : (022) 42469797/ 28518516,
E-mail : sales@socgroup.in

Unit - II: Plot No. 4912, G. I. D. C., Phase IV,
Vatva, Ahmedabad - 382445
Tel.: (079) 40083201/2/3/4,
Fax : (079) 25841056,
E-mail : sales.amd@socgroup.in

Visit us at :
www.speedocontrols.com
www.socremote.com