

MDT 100-18

Mill Duty Thruster Brake

Introduction

Thruster Brake is a device to retard the speed of moving machinery and to stop it accurately to the desired position. The braking force is applied to the brake shoes by a pre-stressed compression spring.

The shoes press on the rotating brake drum retarding its speed, and finally stopping it. Other release devices like pneumatic / hydraulic cylinder or manual release arrangements can be offered on request.

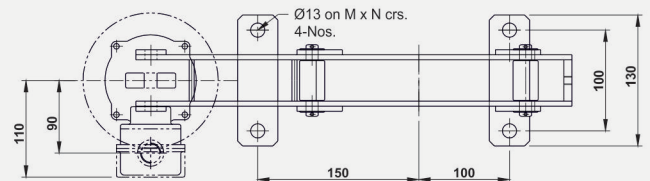
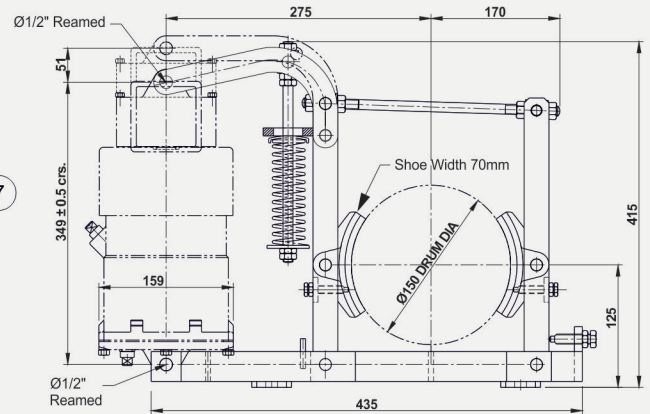
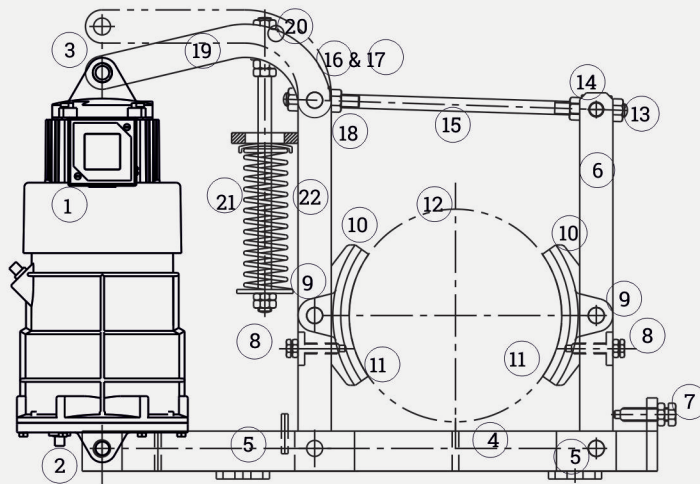

- | | |
|-------------------------------------|---------------------------------------|
| 1. Thruster assembly | 13. Tie-rod adjustment nut & lock-nut |
| 2. Thruster Hinge pin (lower) | 14. Swivel Block |
| 3. Thruster Hinge Pin (Brake lever) | 15. Tie rod or, connecting rod |
| 4. Base Plate | 16. Swivel block for lever |
| 5. Foundation bolt holes | 17. Tie rod Hinge pin |
| 6. Side Arm | 18. Lever hinge pin |
| 7. Side Arm stopper screw | 19. Lever |
| 8. Shoe adjusting screw | 20. Brake Torque Adjustment nuts |
| 9. Shoe hinge pin | 21. Compression Spring |
| 10. Brake shoe | 22. Main Arm |
| 11. Brake liner | |
| 12. Brake Drum (User's supply) | |

Brake Model	Item Code	Brake Drum Dimension (mm)	Braking Torque (kg-m)	Thruster Details		Stroke (mm)	Supply Volts At 50 Hz (V)	Oil Capacity (Litres)	* Mass (kg)
				Model	Lifting Force (kg)				
MDT - 100/18	100100010001	100	6	ST 520	18	50	415	2	17

Supply Voltage 380/480/550/690V available on request

(*) without thruster



Speed-O-Controls Pvt. Ltd.

H. O. Unit - I : C-15/16, Nand Jyot Industrial Estate, Andheri-Kurla Road, Mumbai - 400072,
Tel : (022) 42469700-30, 28518512-3-4,
Fax : (022) 42469797/ 28518516,
E-mail : sales@socgroup.in

Unit - II : Plot No. 4912, G. I. D. C., Phase IV, Vatva, Ahmedabad - 382445
Tel.: (079) 40083201/2/3/4,
Fax : (079) 25841056,
E-mail : sales.amd@socgroup.in

Visit us at :
www.speedocontrols.com
www.socremote.com