



Features	Code
Brake Disc	B
Form	F B S
Size of Brake Discs according to table	0125 to 1000
Thickness of brake disc (Standard)	12 25
Bore diameter according to table	014 to 220
Form pre drilled, finished bore without keyway, finished bore with keyway	V F B

Example for ordering

Brake Disc BF with a size of Brake Disc 200 mm, thickness of brake disc 12,5 mm and bore diameter 40 mm in Form F:

BF 0200/12 - 040 F

Technical Data

Size D mm	Thickness of brake disc W mm	Max. speed n_{max} min^{-1}	Form F Inertia moment J kgm^2	Form B Inertia moment J kgm^2	Form S*		
					Clamping diameter d mm	Inertia moment J kgm^2	Max. braking torque M_{max} Nm
125	12,5	14 500	0,0022	0,0023	-	-	-
150	12,5	12 100	0,0045	0,0047	-	-	-
200	12,5	9 100	0,0141	0,0146	-	-	-
250	12,5	7 300	0,0345	0,0380	-	-	-
300	12,5	6 000	0,0720	0,0800	80	0,078	950
355	12,5 / 25	5 100	0,140 / 0,270	0,162 / 0,243	-	-	-
430	12,5 / 25	4 200	0,302 / 0,596	0,352 / 0,638	90	0,305	1 500
					140	0,405	3 750
					160	0,646	6 000
520	12,5 / 25	3 500	0,646 / 1,273	0,790 / 1,380	140	0,752	3 750
					160	0,990	6 000
					200	1,431	9 500
630	25	2 900	2,780	3,130	-	-	-
710	25	2 600	4,490	5,090	-	-	-
800	25	2 300	7,240	8,420	-	-	-
900	25	2 000	11,59	13,70	-	-	-
1 000	25	1 800	17,70	21,30	-	-	-

* Only available in thickness of brake disc W = 12,5 mm

Features

- Optimized for use with RINGSPANN Brakes
- Cast material for best heat absorption
- Ready to install versions are available
- Variants with finished bore, keyway or shrink disc
- Disk diameter ranging from 125 mm to 1000 mm
- The Brake Disc are made from EN 1563 EN-GJS500-7 (GGG-50 after DIN 1693)
- Other sizes of Brake Discs are available on request

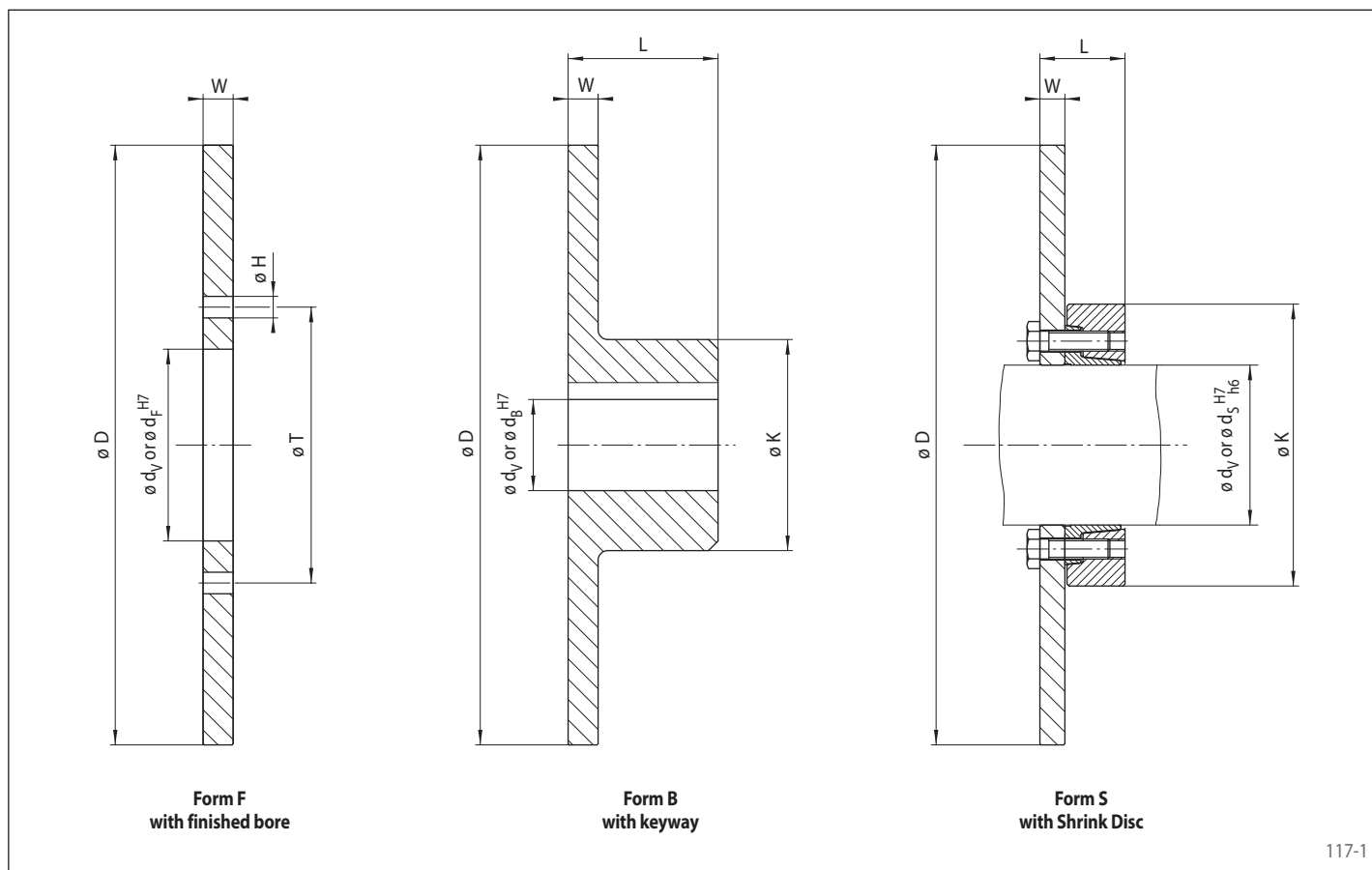

117-1

Dimensions

Size	Thickness of brake disc	Pre drilled	Form F				Form B			Form S		
			Finished bore d_F	H	T	Z*	Max. finished bore d_B^{**}	L	K	Clamping diameter d_S	L***	K
D mm	W mm	d_V mm	d_F mm	H mm	T mm	Z*	d_B^{**} mm	L mm	K mm	d_S mm	L*** mm	K mm
125	12,5	-	40	9	56	4	32	37,5	50	-	-	-
150	12,5	-	50	9	66	4	40	42,5	60	-	-	-
200	12,5	-	63	11	83	8	45	52,5	65	-	-	-
250	12,5	-	80	11	100	8	70	62,5	100	-	-	-
300	12,5	-	100	14	122	8	80	72,5	120	80	46,5	141
355	12,5 / 25	-	110	14	132	10	100	82,5	145	-	-	-
430	12,5 / 25	50	125	14	147	12	115	97,5	170	90	52,5	155
										140	74,5	230
										160	84,5	290
										140	74,5	230
520	12,5 / 25	50	160	14	182	16	140	117,5	210	160	84,5	290
										160	84,5	290
										200	101,5	340
										-	-	-
630	25	75	-	-	-	-	155	150	250	-	-	-
710	25	95	-	-	-	-	180	165	280	-	-	-
800	25	95	-	-	-	-	200	185	320	-	-	-
900	25	120	-	-	-	-	210	205	360	-	-	-
1000	25	120	-	-	-	-	220	225	400	-	-	-

* Z = Number of holes ϕH pitch circle ϕT • ** Keyway according to DIN 6885, page 1 • *** At unclamped state

Brake Discs Form S

The following apply to the shaft:

- Yield strength $R_e \geq 360 \text{ N/mm}^2$
- E-module ca. 206 kN/mm^2

Surfaces

Average surface roughness at the contact surfaces of the shaft $R_a \leq 3,2 \mu\text{m}$.

Dimensioning

Please refer to the technical points on page 119 when dimensioning the brake disc size.

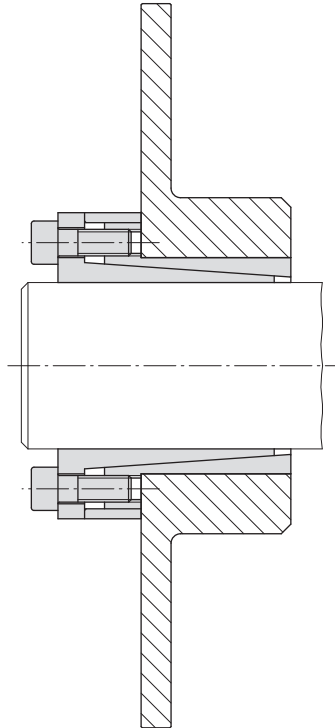

**Cone Clamping Element RLK 110
with Brake Disc Form B**

118-1

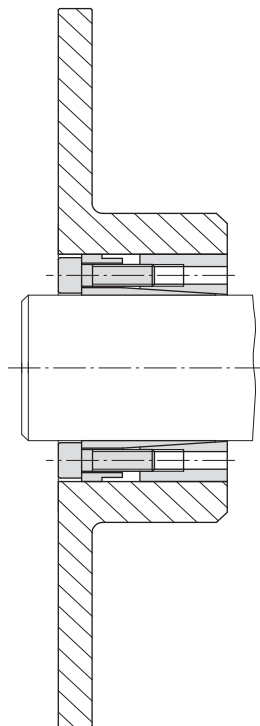

**Cone Clamping Element RLK 130
with Brake Disc Form B**

118-2

Verification of Heat Absorption

Permissible Braking Action with Single Braking Operation

Extreme braking processes should be checked to ensure that the brake disc will not reach 300°C when absorbing the braking energy. The braking time in this case should not exceed 10 seconds.

The maximum energy of braking to be absorbed for brake discs made from GGG-50 is given in the table. We recommend that this additional calculation be carried out in the case of indexing operations. The absorbed energy for the deceleration of rotating masses in this case is:

$$W_B = \frac{J_{red} (n_1 - n_2)^2}{182,5}$$

Ensure that:

$$W_{BSzul} \geq W_B$$

D mm	W_{BSzul} Nm
125	185 000
150	270 000
200	460 000
250	760 000
300	1 300 000
355	1 900 000
430	3 000 000
520	5 000 000
630	11 000 000
710	15 000 000
800	20 000 000
900	27 000 000
1 000	35 000 000

Verification of Heat Dissipation

The transmissible brake power of the disc according to the diagram on this page applies to the types of braking operation described below:

$$P_{BSzul} \geq P_B$$

Braking with low frequency $z \leq 40$ per hour

If „z“ actuations occur within one hour, then the brake power capacity required is as follows:

$$P_B = \frac{M_B (n_1 - n_2)}{6,88 \cdot 10^7} \cdot z \cdot t_B$$

Braking with high frequency $z > 40$ per hour

For such cases we would ask you to enclose with your enquiry exact details of the time slope of speed and braking torque, as well as the completed questionnaire on page 134. We will check the design of the brake disc in respect of the heat dissipation.

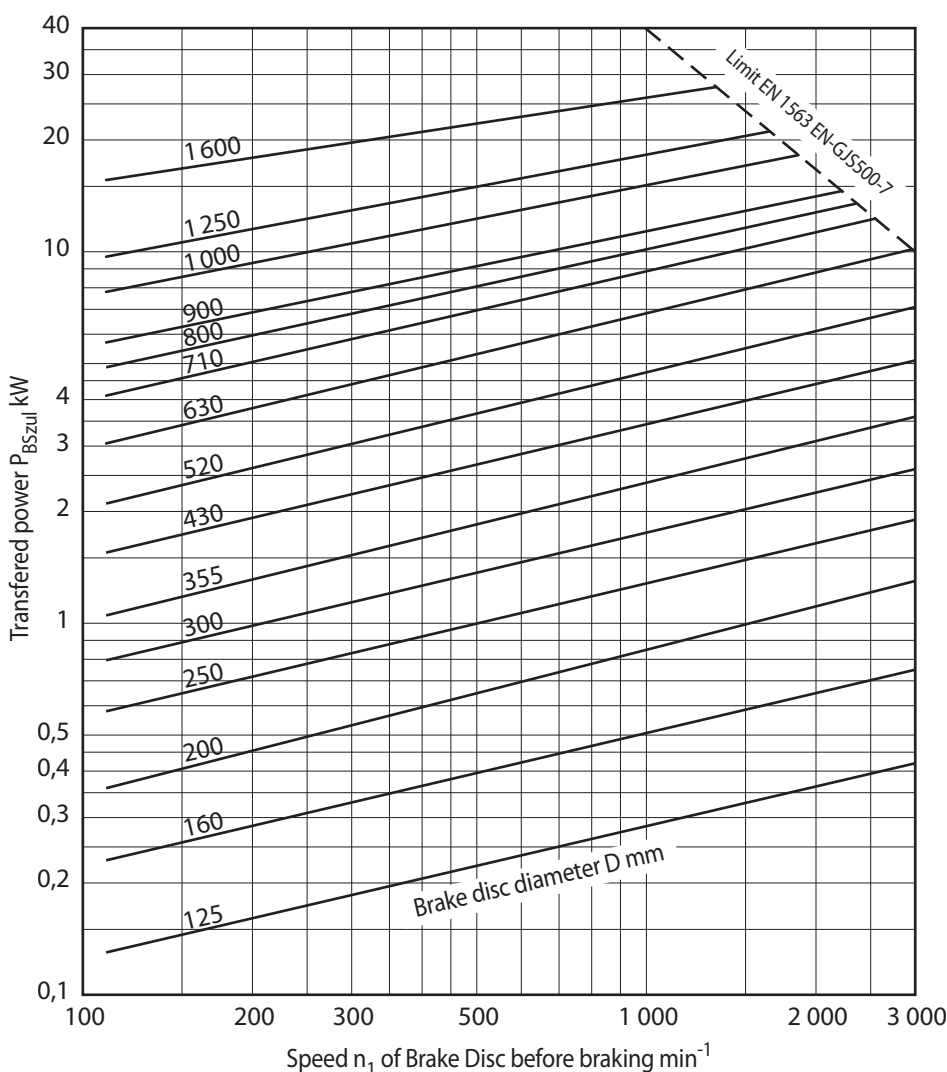

Formula symbols

- J_{red} [kg m²] Reduced inertia moment
- M_B [Nm] Required braking torque
- n_1 [min⁻¹] Speed before braking
- n_2 [min⁻¹] Speed after braking
- P_B [kW] Brake power generated by application, average with one braking cycle
- P_{BSzul} [kW] Brake power capacity of brake
- t_B [s] Braking time
- W_B [Nm] Braking energy generated by application
- W_{BSzul} [Nm] Braking energy capacity of the disc brake
- z [h⁻¹] Number of braking cycles per hour

The transferred power is based on a maximum disc temperature of 300 °C applicable to Brake Disc thicknesses of up to 25 mm.