

Brake Caliper DH 020 PFK

pneumatically activated – spring released

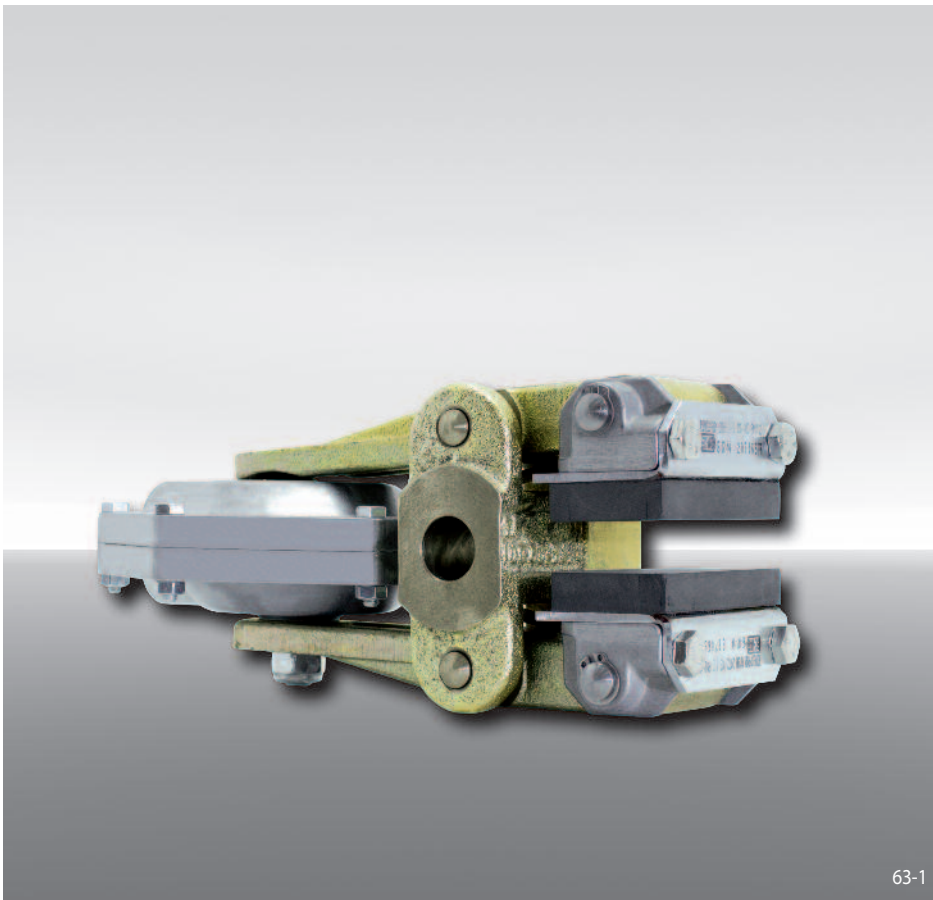

63-1

Features

Features	Code
Brake Caliper	D
Mounting to the machine at right angles to the brake disc	H
Frame size 020	020
Pneumatically activated	P
Spring released	F
No adjustment to accommodate friction block wear	K
Thruster 630	630
Thruster mounted in central position	M
Thickness of brake disc 12,5 mm	12

Example for ordering

Brake Caliper DH 020 PFK, thruster 630, thruster mounted in central position, thickness of brake disc 12,5 mm:

DH 020 PFK - 630 M - 12

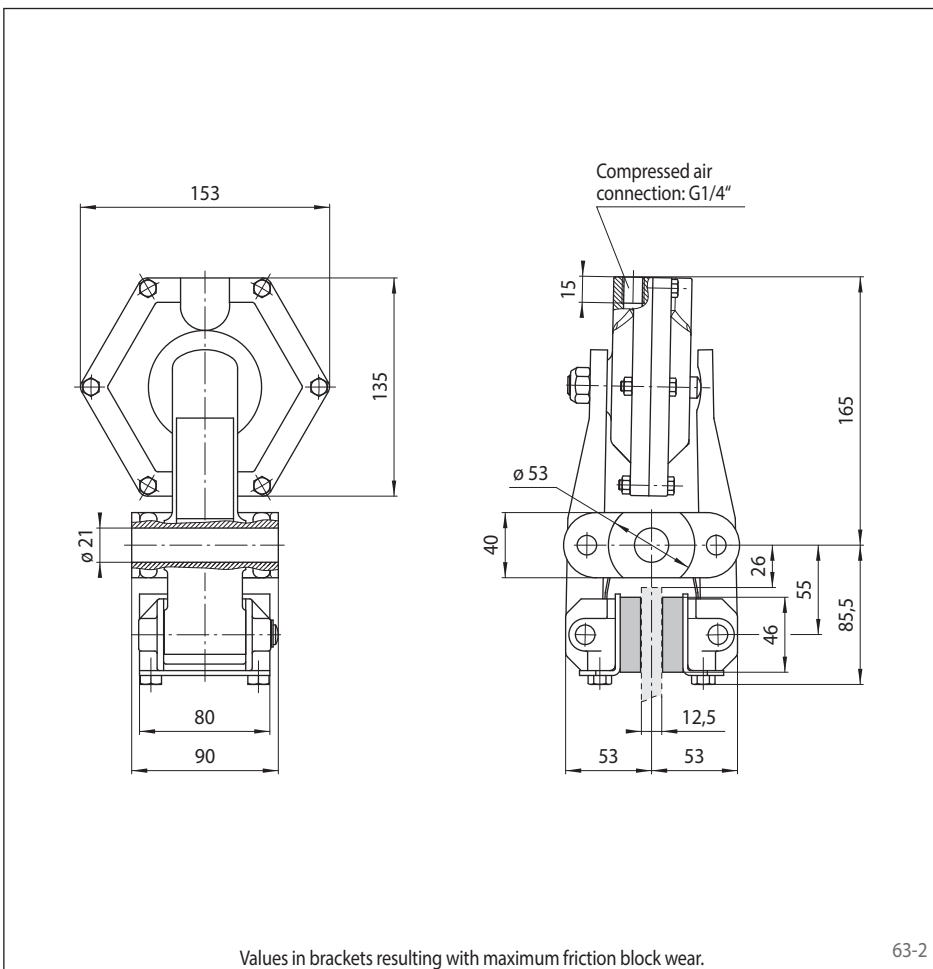

63-2

Technical Data

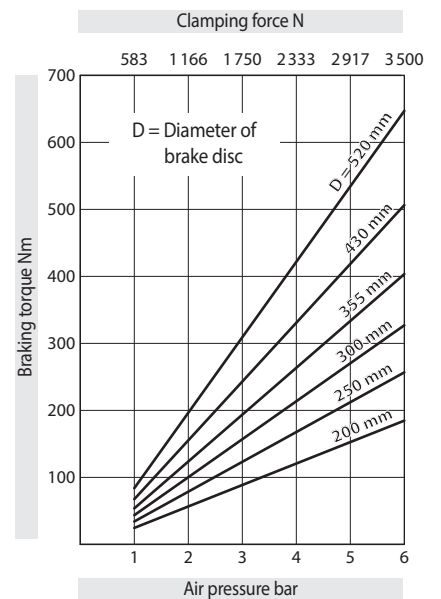

The braking torques shown in the diagram are based on a theoretical friction coefficient of 0,4.

Air pressure: max. 6 bar

Air volume: max. 120 cm³ per activation

Weight: 4,8 kg