

Brake Caliper DH 025 PFM

pneumatically activated – spring released

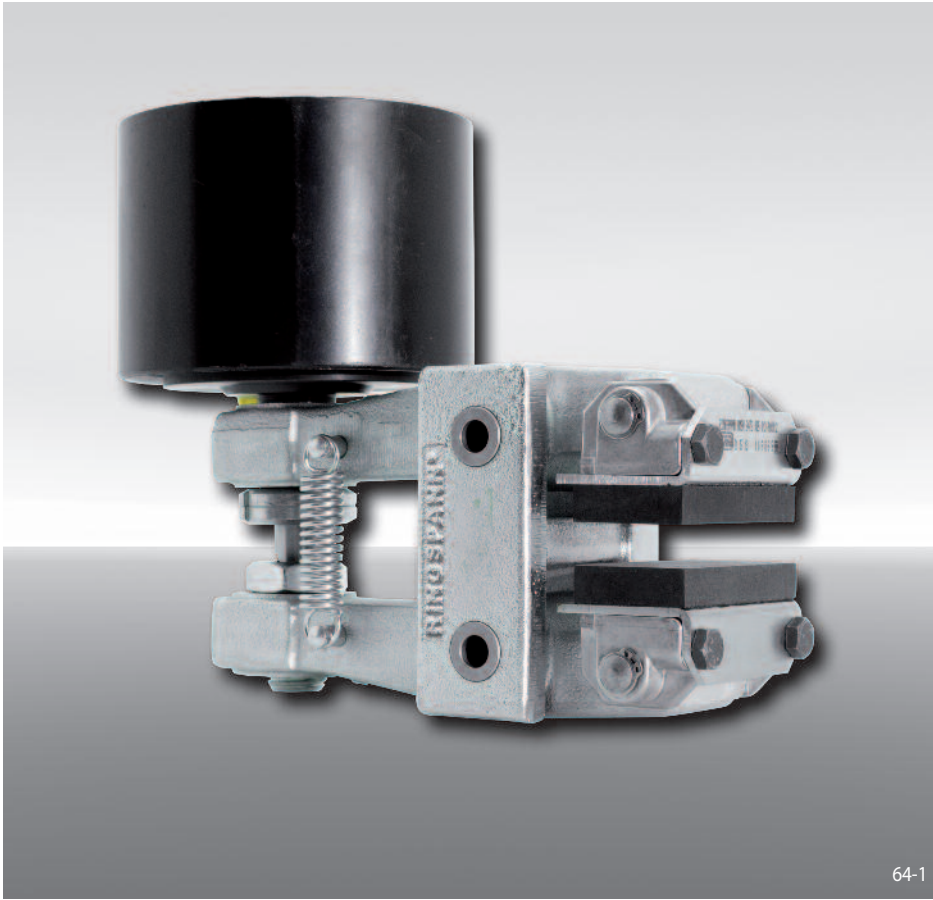

Features

Features	Code
Brake Caliper	D
Mounting to the machine at right angles to the brake disc	H
Frame size 025	025
Pneumatically activated	P
Spring released	F
Manual adjustment to accommodate friction block wear	M
Thrusters 635 or 655 are available	635 655
Thruster mounted right or left available	R L
Thickness of brake disc 12,5 mm or 25 mm	12 25

Example for ordering

Brake Caliper DH 025 PFM, thruster 635, thruster mounted right, thickness of brake disc 12,5 mm:

DH 025 PFM - 635 R - 12

Technical Data

Brake Caliper DH 025 PFM - 635

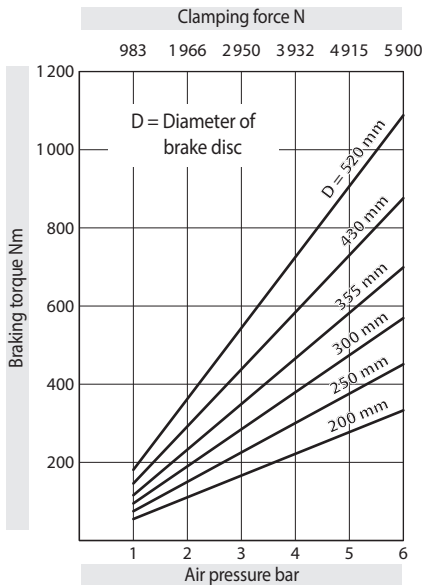

The braking torques shown in the diagram are based on a theoretical friction coefficient of 0,4.

Air pressure: max. 6 bar

Air volume: max. 175 cm³ per activation

Weight: 7,1 kg

Brake Caliper DH 025 PFM - 655

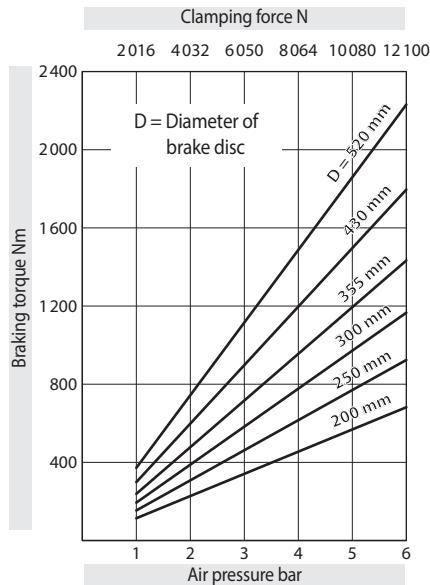

The braking torques shown in the diagram are based on a theoretical friction coefficient of 0,4.

Air pressure: max. 6 bar

Air volume: max. 740 cm³ per activation

Weight: 10,3 kg

Brake Caliper DH 025 PFM

pneumatically activated – spring released

