

Brake Caliper DH 035 PFM

pneumatically activated – spring released

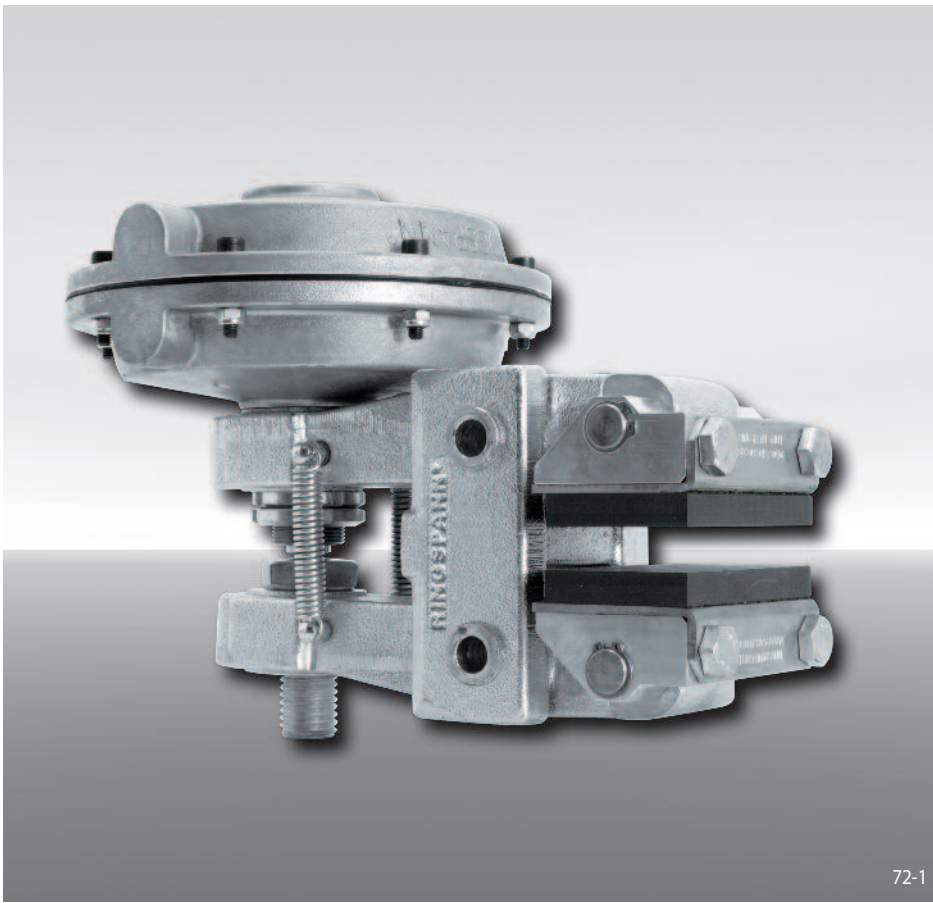

Features

Features	Code
Brake Caliper	D
Mounting to the machine at right angles to the brake disc	H
Frame size 035	035
Pneumatically activated	P
Spring released	F
Manual adjustment to accommodate friction block wear	M
Thrusters 635, 655 or 660 are available	635 655 660
Thruster mounted right or left available	R L
Thickness of brake disc 12,5 mm, 25 mm, 30 mm or 40 mm	12 to 40

Example for ordering

Brake Caliper DH 035 PFM, thruster 660, thruster mounted right, thickness of brake disc 12,5 mm:

DH 035 PFM - 660 R - 12

Technical Data

Brake Caliper DH 035 PFM - 635

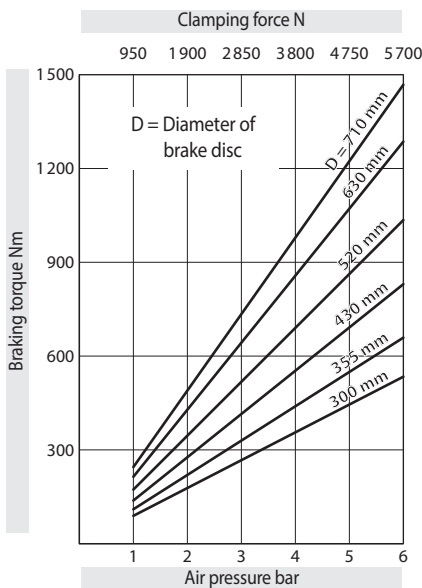

The braking torques shown in the diagram are based on a theoretical friction coefficient of 0,4.

Air pressure: max. 6 bar

Air volume: max. 175 cm³ per activation

Weight: 9,1 kg

Brake Caliper DH 035 PFM - 655

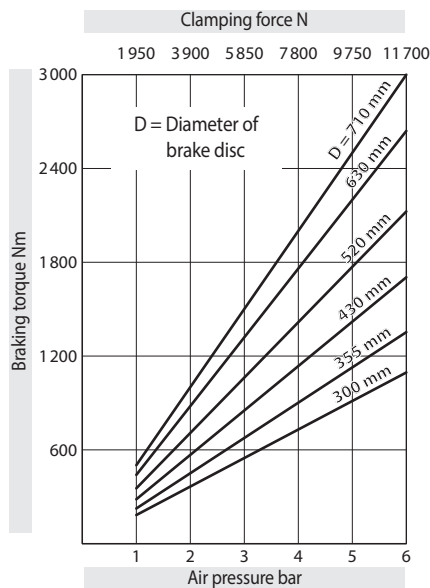

The braking torques shown in the diagram are based on a theoretical friction coefficient of 0,4.

Air pressure: max. 6 bar

Air volume: max. 740 cm³ per activation

Weight: 12,3 kg

Brake Caliper DH 035 PFM - 660

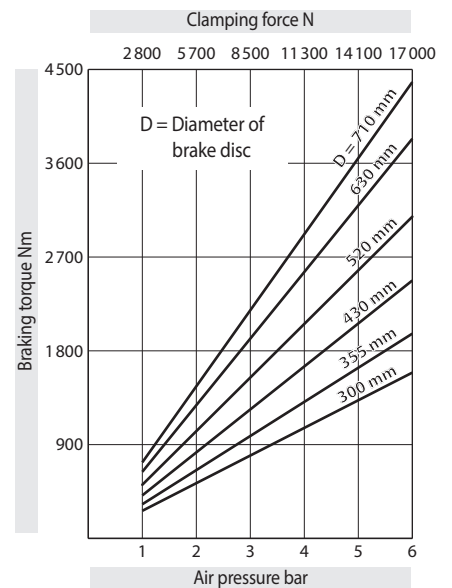

The braking torques shown in the diagram are based on a theoretical friction coefficient of 0,4.

Air pressure: max. 6 bar

Air volume: max. 450 cm³ per activation

Weight: 11,4 kg

Brake Caliper DH 035 PFM

pneumatically activated – spring released

