

Brake Caliper DU 060 FHM

spring activated – hydraulically released

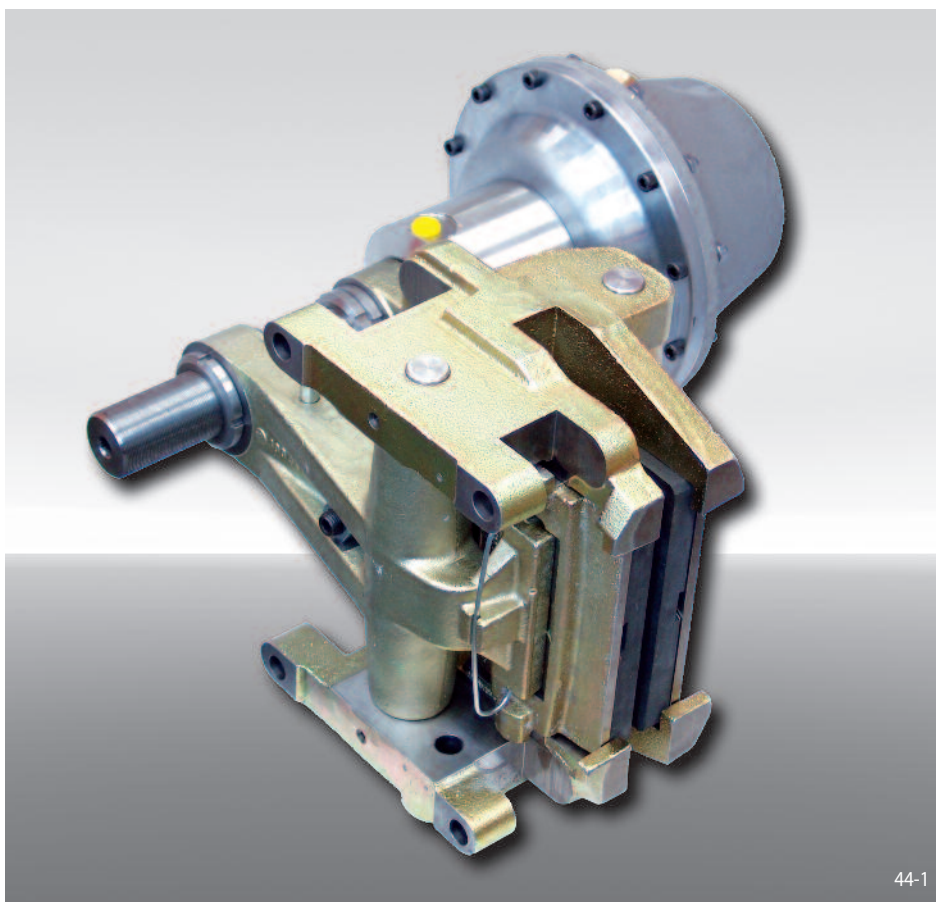

Features

Features	Code
Brake Caliper	D
Mounting to the machine, can be made either parallel or at the right angles to the brake disc	U
Frame size 060	060
Spring activated	F
Hydraulically released	H
Manual adjustment to accommodate friction block wear	M
Thrusters 340, 350, 360 or 370 are available	340 to 370
Thruster mounted right or left available	R L
Thickness of brake disc 25 mm or 40 mm	25 40

Example for ordering

Brake Caliper DU 060 FHM, thruster 340, thruster mounted right, thickness of brake disc 25 mm:

DU 060 FHM - 340 R - 25

Technical Data

	Brake Caliper DU 060 FHM			
	with thruster 340	with thruster 350	with thruster 360	with thruster 370
Brake disc diameter	Braking torque	Braking torque	Braking torque	Braking torque
mm	Nm	Nm	Nm	Nm
630	2700	5400	7800	13500
710	3100	6200	9000	15500
800	3600	7200	10300	17500
900	4100	8300	11900	20500
1000	4700	9300	13400	23000
1250	6000	12000	17000	29500
1600	7800	15500	22500	38500
Clamping force	13200 N	26500 N	38000 N	65000 N
Oil pressure	min. 20 bar max. 125 bar	min. 30 bar max. 125 bar	min. 50 bar max. 125 bar	min. 80 bar max. 125 bar
Oil volume	max. 158 cm ³	max. 158 cm ³	max. 158 cm ³	max. 158 cm ³
Weight	71 kg	71 kg	71 kg	71 kg

The braking torques shown in the table are based on a theoretical friction coefficient of 0,4.

Brake Caliper DU 060 FHM

spring activated – hydraulically released

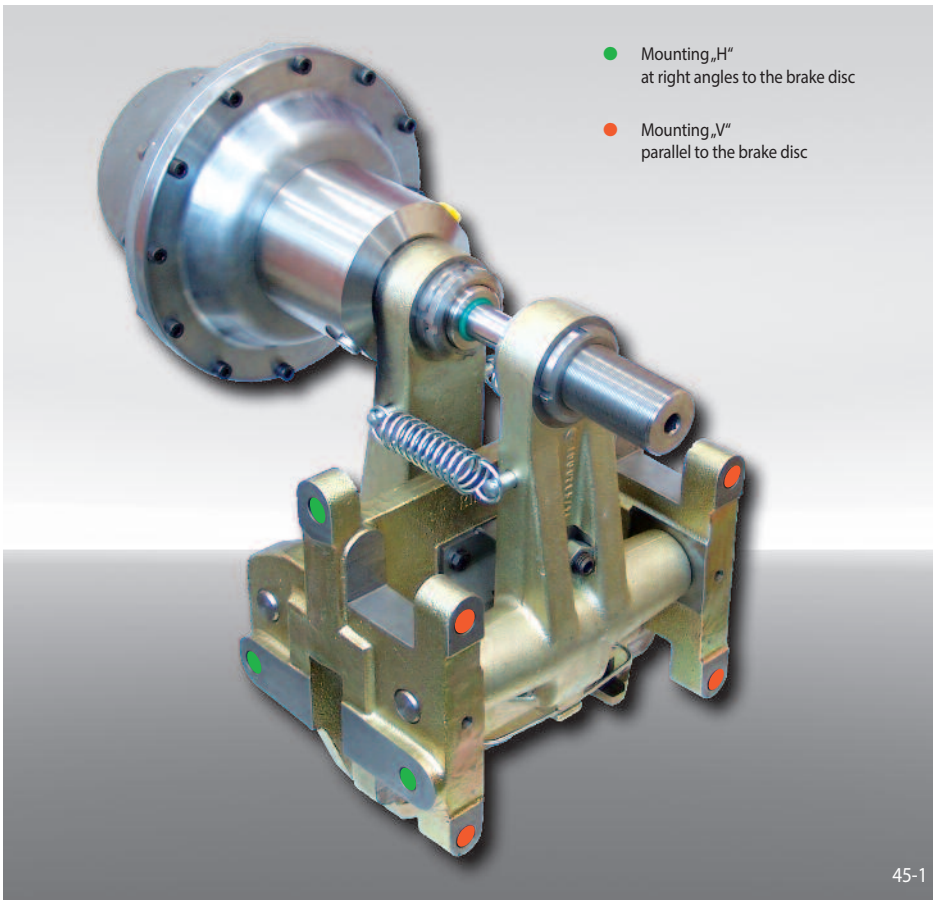

- Mounting „H“ at right angles to the brake disc
- Mounting „V“ parallel to the brake disc

Frame Design

