

Brake Caliper DV 020 FEM

spring activated – electromagnetically released

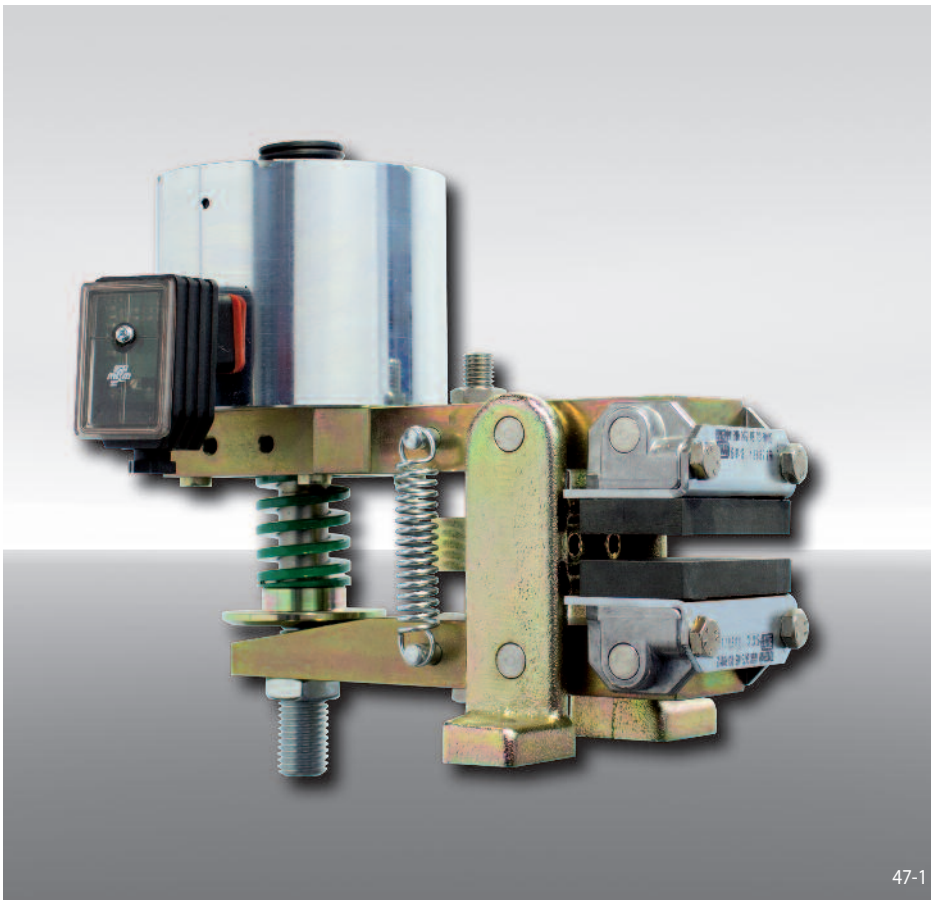

47-1

Features

Features	Code
Brake Caliper	D
Mounting to the machine parallel to the brake disc	V
Frame size 020	020
Spring activated	F
Electromagnetically released	E
Manual adjustment to accommodate friction block wear	M
Electromagnet for 230 V	430
Thruster mounted right or left available	R L
Thickness of brake disc 12,5 mm	12

Example for ordering

Brake Caliper DV 020 FEM, electromagnet for 230 V, thruster mounted right, thickness of brake disc 12,5 mm:

DV 020 FEM - 430 R - 12

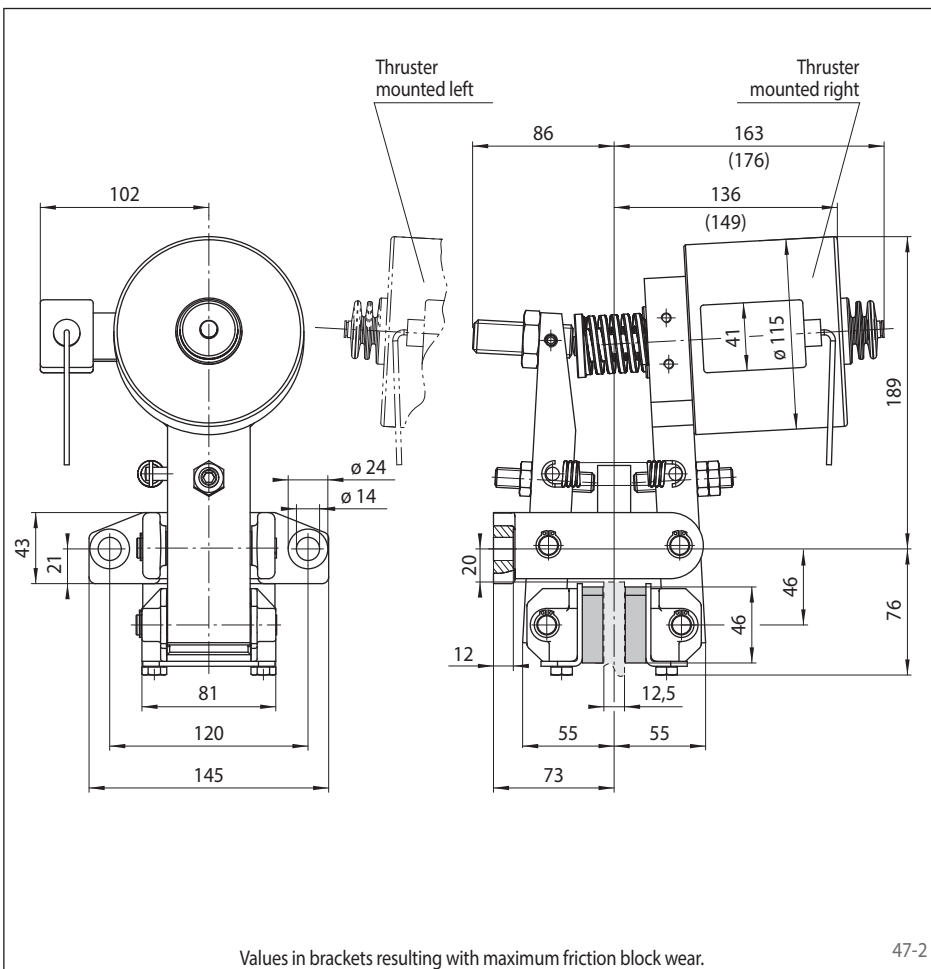

47-2

Technical Data

Brake Caliper DV 020 FEM with electromagnet 430 for 230 V	
Brake disc diameter	Braking torque
mm	Nm
200	180
250	240
300	300
355	370
430	460
520	570
Clamping force	3 100 N
Power consumption in open position	12 W (100% duty factor)
Fuse rating	6 A
Switching frequency	800/h permanent activations at 20° C ambient temperature
Weight	15 kg

The braking torques shown in the table are based on a theoretical friction coefficient of 0,4.

Accessories

Universal Transformer see page 120.