

Brake Caliper DV 020 MKM

manually activated – manually released
by Pull Cable

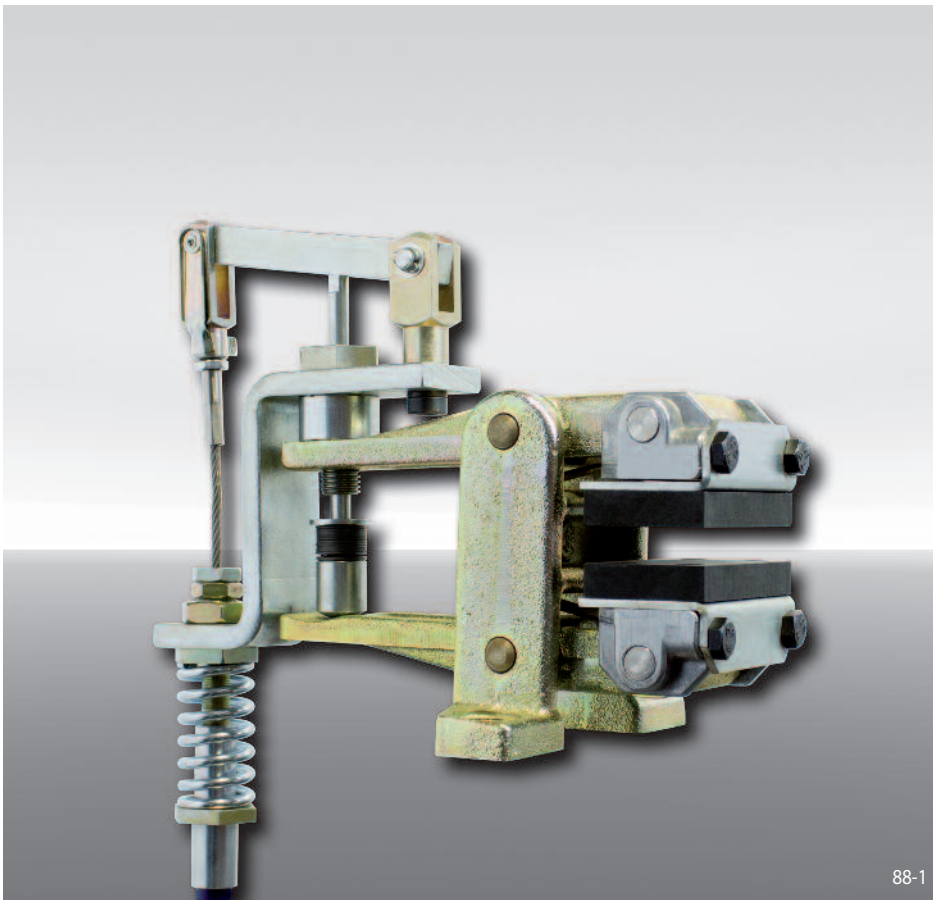

Features

Features	Code
Brake Caliper	D
Mounting to the machine parallel to the brake disc	V
Frame size 020	020
Manually activated	M
Manually released	K
Manual adjustment to accommodate friction block wear	M
Spring-loaded pressure pin 730	730
Pull cable installation mounted right or left available	R L
Thickness of brake disc 12,5 mm	12

Example for ordering

Brake Caliper DV 020 MKM, pressure pin 730, pull cable installation mounted right, thickness of brake disc 12,5 mm:

DV 020 MKM - 730 R - 12

Technical Data

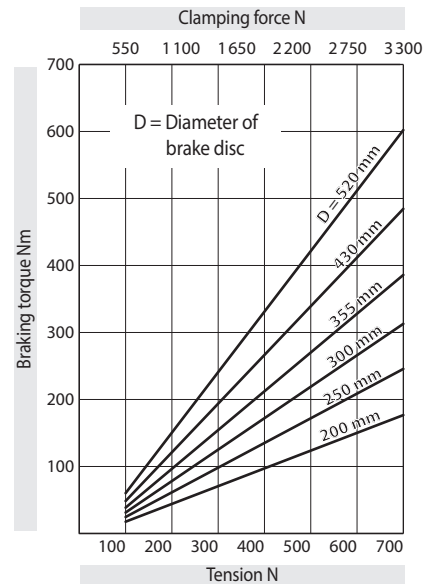
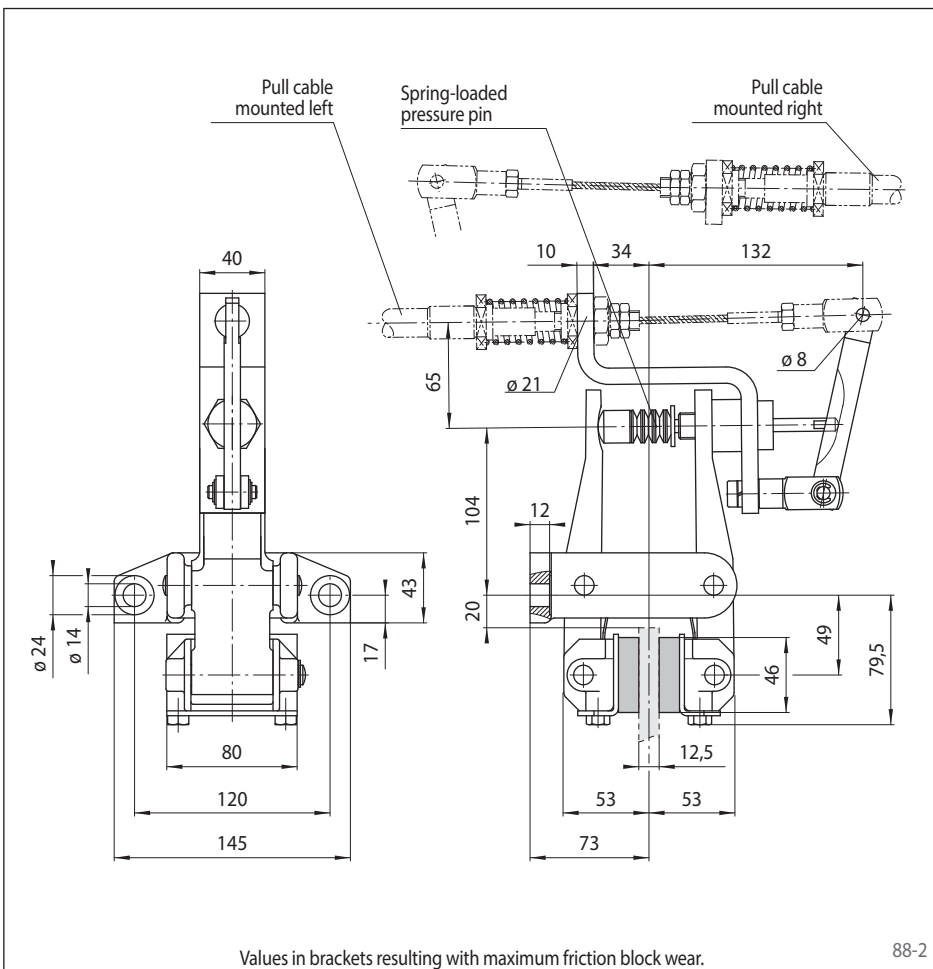

The braking torques shown in the diagram are based on a theoretical friction coefficient of 0,4.

Weight: 5,1 kg

Accessories

The Brake Caliper can be delivered fully assembled with RCS® Pull Cable and Hand Brake Lever. Please indicate the required cable length.

For further information regarding RCS® Pull Cables and Hand Brake Lever see page 121.

A spring loaded pressure pin compensates for wear of the friction block during the braking action.