

# Brake Calipers EV 018 EFM and EH 018 EFM

electromagnetically activated – spring released

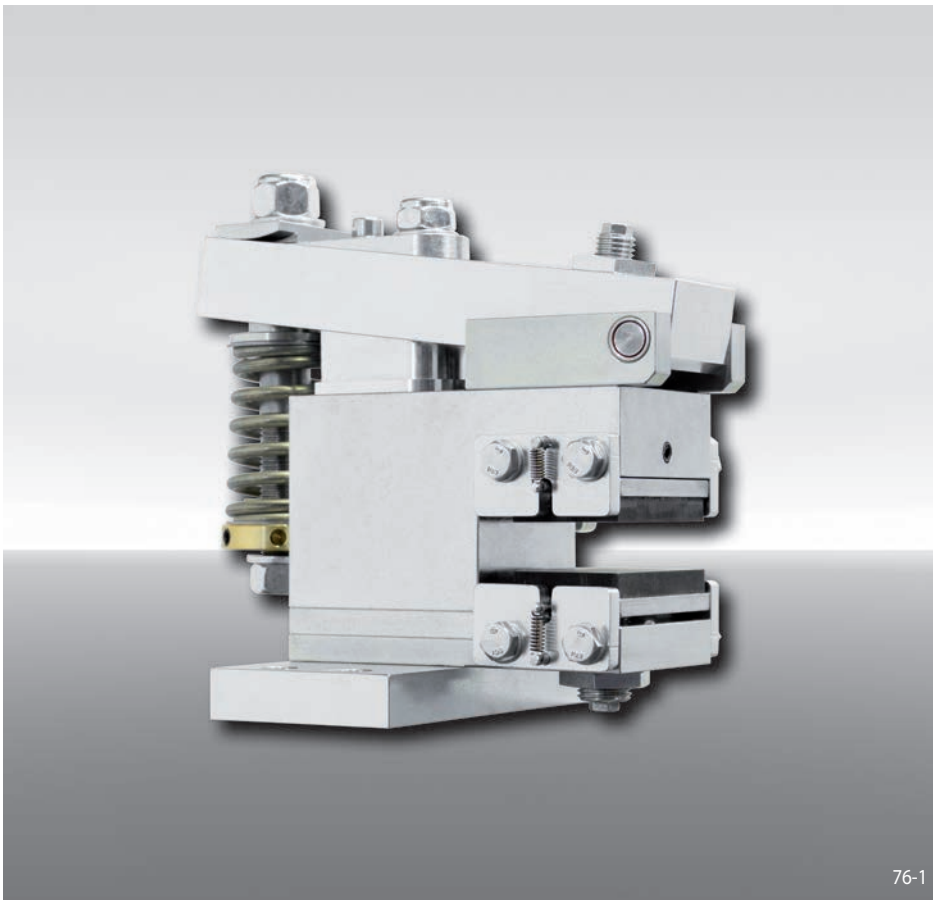

76-1

## Features

Features	Code
Brake Caliper with electromagnet	E
Mounting to the machine parallel or at right angles to the brake disc	V H
Frame size 018	018
Electromagnetically activated	E
Spring released	F
Manual adjustment to accommodate friction block wear	M
Supply voltage 230 to 415 VAC, supply frequency 50 Hz or 60 Hz adjustable	400
Electromagnet mounted in central position	M
Thickness of brake disc 8 ... 15 mm or 16 ... 20 mm	12 20

## Example for ordering

Brake Caliper EV 018 EFM, supply voltage 400 VAC, electromagnet mounted in central position, thickness of brake disc 15 mm:

EV 018 EFM - 400 M - 12

## Advantages

The brake caliper EV 018 EFM or EH 018 EFM is a very compact and high efficient disc brake with very low power consumption. Its floating bearing compensates small misalignments of the brake disc. The separate electronic module (included) reduces automatically the power consumption in closed position to 10 W.

## Options

- Inductive proximity switch: "Brake released"-, "Brake closed"-status and/or "Friction block wear adjustment necessary"

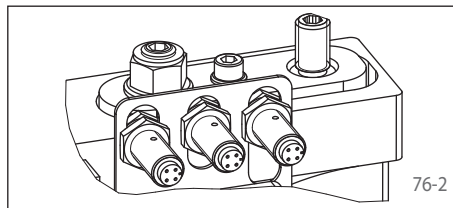

76-2

## Electronic module

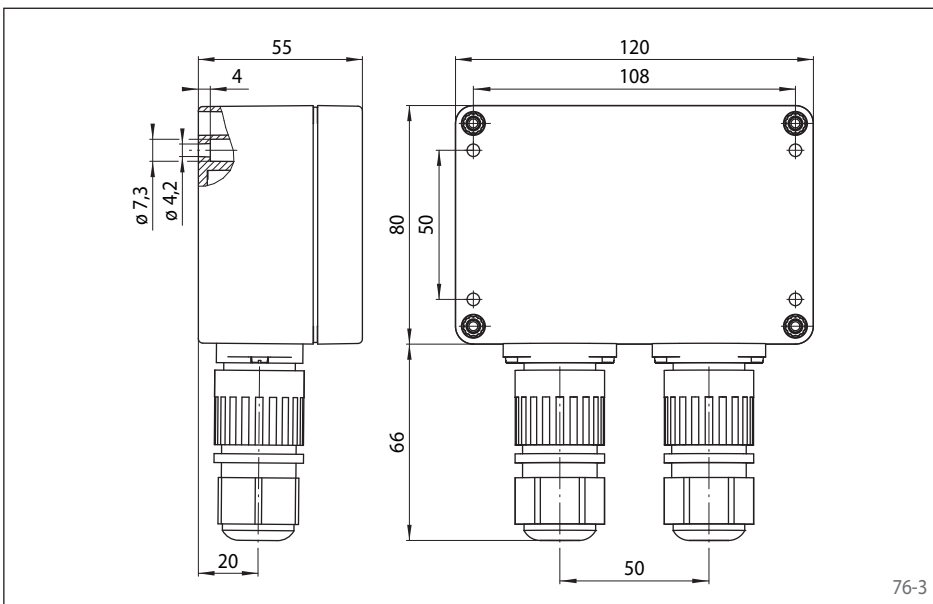

76-3

## Technical Data

	Brake Calipers EV 018 EFM and EH 018 EFM with supply voltage	
	230/240 VAC	380/400/415 VAC
Brake disc diameter	Braking torque	Braking torque
mm	Nm	Nm
125	60	95
150	75	125
200	110	185
250	150	245
300	180	305
355	220	370
Clamping force	1800 N	3000 N
Clamping force or braking torque adjustable	70 - 100%	50 - 100%
Power consumption in closed position	10 W (100% duty factor)	
Fuse rating	16A, time-lag	
Switching frequency	240/h permanent activations at 20° C ambient temperature	
Switching time*	at least 10 seconds	
Weight	6,5 kg	

The braking torques shown in the table are based on a theoretical friction coefficient of 0,4.

\* shorter switching time on request

# Brake Calipers EV 018 EFM and EH 018 EFM

electromagnetically activated – spring released

## Brake Caliper EV 018 EFM

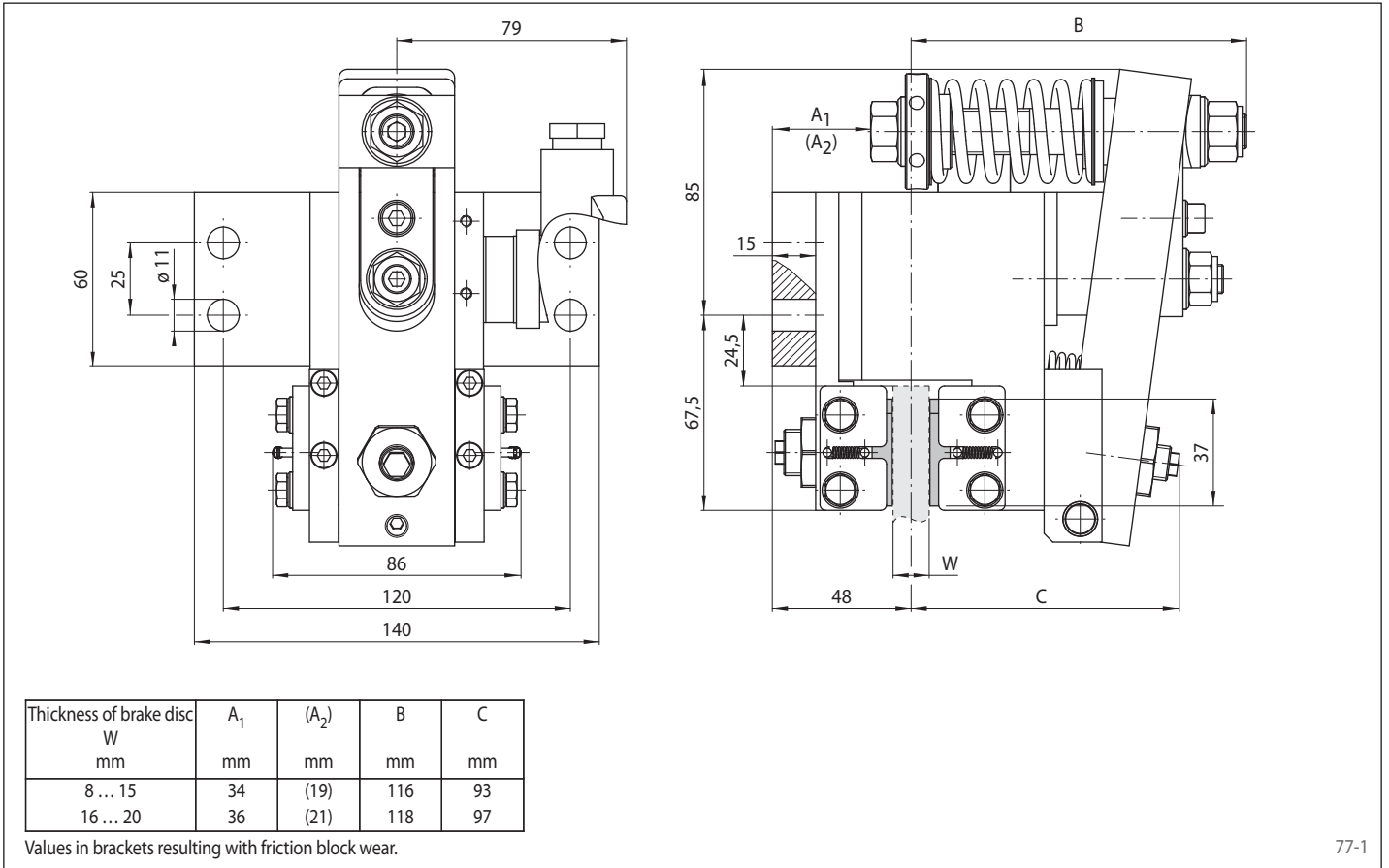

77-1

## Brake Caliper EH 018 EFM

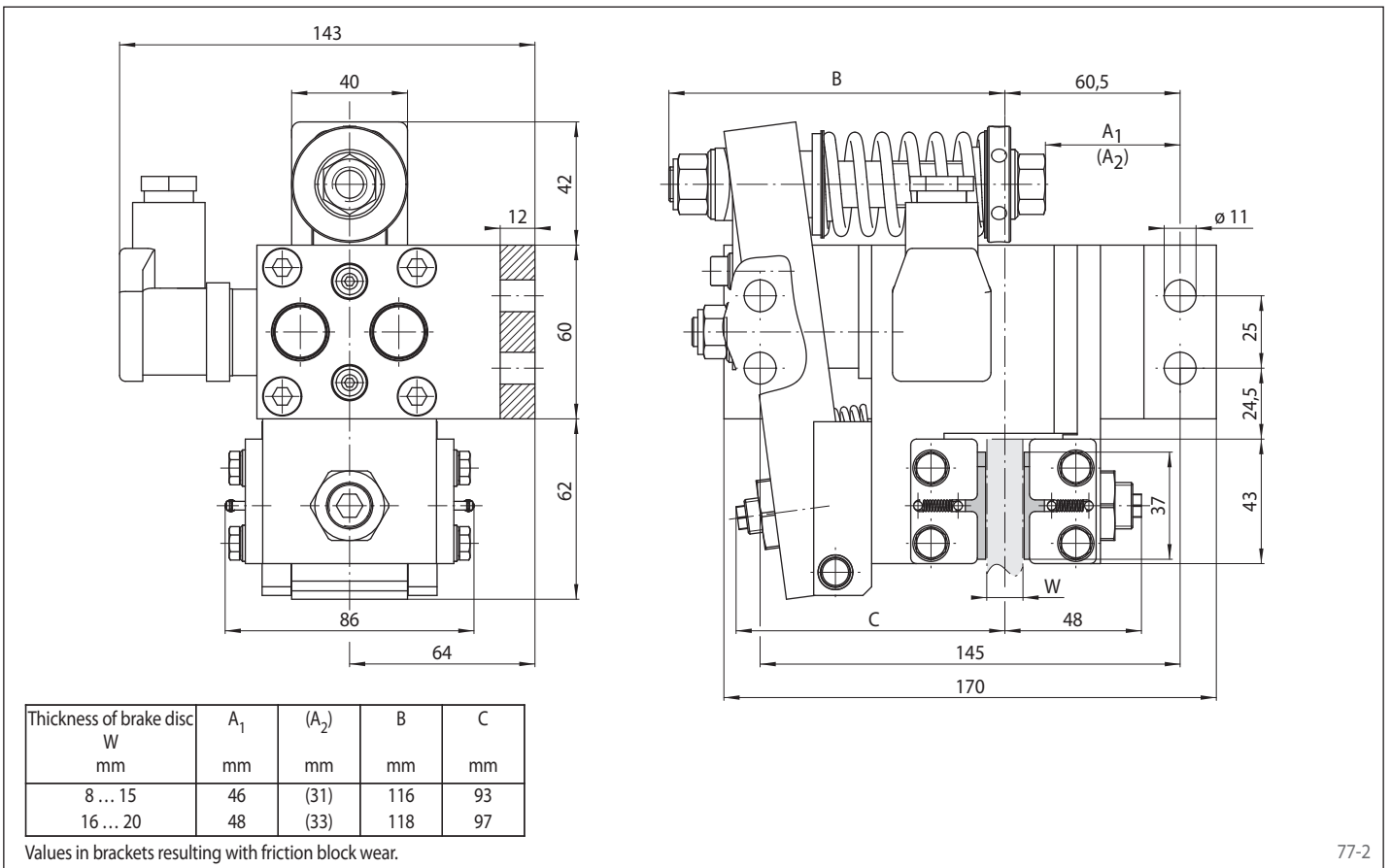

77-2