

Brake Calipers EV 018 FEM and EH 018 FEM

spring activated – electromagnetically released

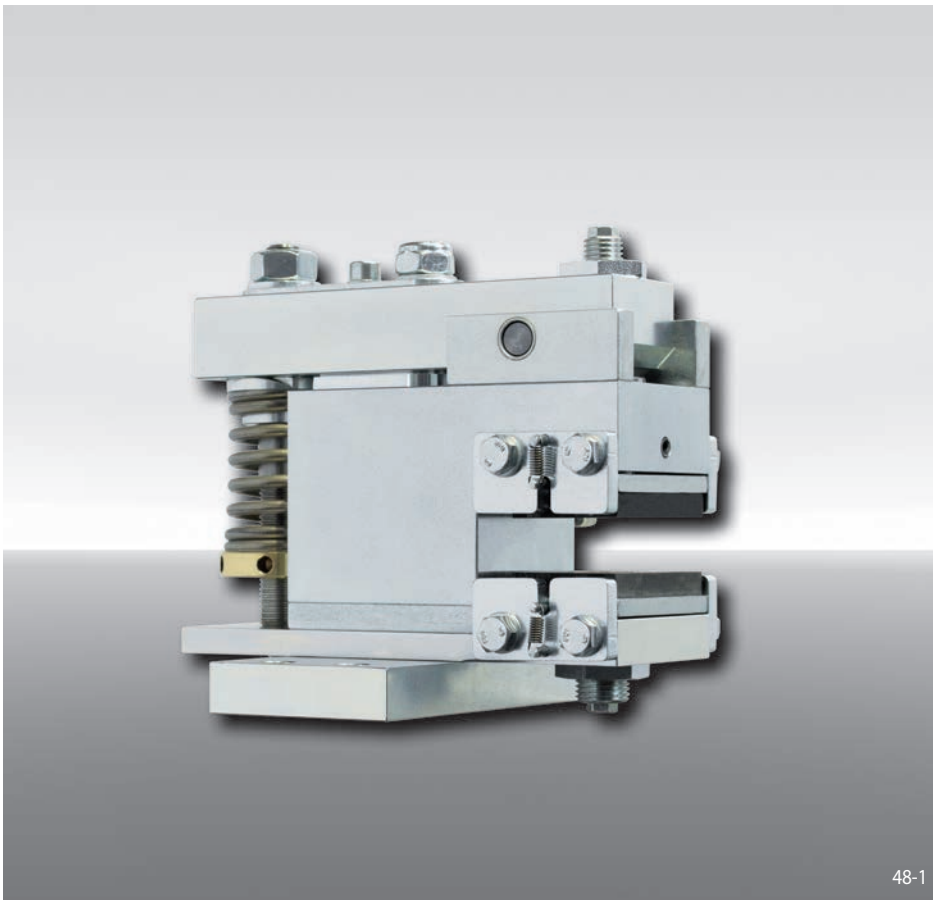

48-1

Advantages

The brake caliper EV 018 FEM or EH 018 FEM is a very compact and high efficient disc brake with very low power consumption. Its floating bearing compensates small misalignments of the brake disc. The separate electronic module (included) reduces automatically the power consumption in open position to 10 W.

Options

- Inductive proximity switch: "Brake released"-, "Brake closed"-status and/or "Friction block wear adjustment necessary"

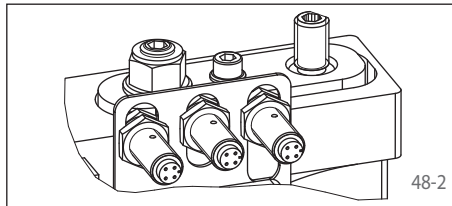

48-2

Electronic module

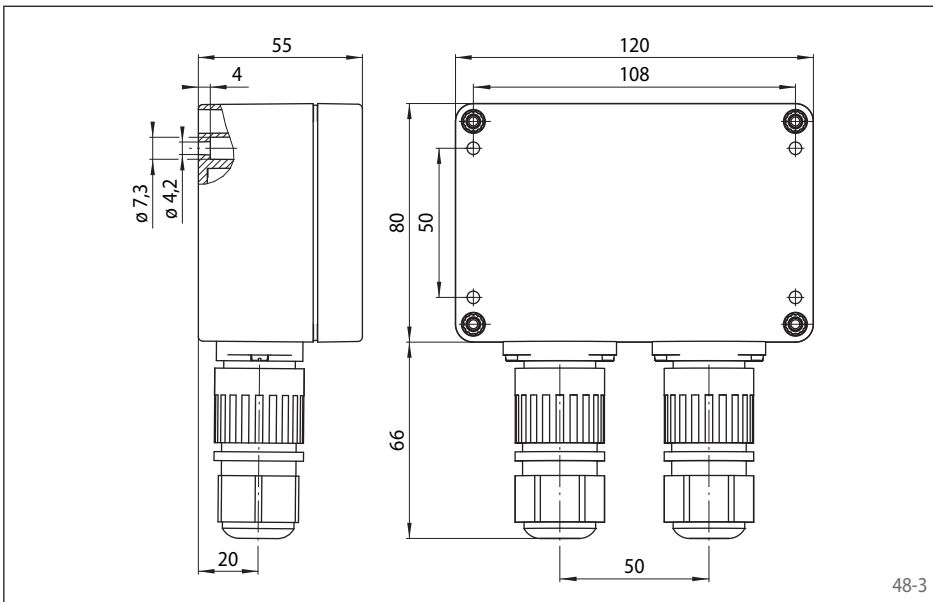

48-3

Features

Features	Code
Brake Caliper with electromagnet	E
Mounting to the machine parallel or at right angles to the brake disc	V H
Frame size 018	018
Spring activated	F
Electromagnetically released	E
Manual adjustment to accommodate friction block wear	M
Supply voltage 230 to 415 VAC, supply frequency 50 Hz or 60 Hz adjustable	400
Electromagnet mounted in central position	M
Thickness of brake disc 8 ... 15 mm or 16 ... 20 mm	12 20

Example for ordering

Brake Caliper EV 018 FEM, supply voltage 400 VAC, electromagnet mounted in central position, thickness of brake disc 15 mm:

EV 018 FEM - 400 M - 12

Technical Data

	Brake Calipers EV 018 FEM and EH 018 FEM with supply voltage	
	230/240 VAC	380/400/415 VAC
Brake disc diameter	Braking torque	Braking torque
mm	Nm	Nm
125	65	90
150	90	120
200	130	180
250	170	240
300	215	295
355	260	360
Clamping force	2 100 N	2 900 N
Clamping force or braking torque adjustable	60 - 100%	50 - 100%
Power consumption in open position	30 W (100% duty factor)	
Fuse rating	16A, time-lag	
Switching frequency	240/h permanent activations at 20° C ambient temperature	
Switching time*	at least 10 seconds	
Gewicht	6,5 kg	

The braking torques shown in the table are based on a theoretical friction coefficient of 0,4.

* shorter switching time on request

Brake Calipers EV 018 FEM and EH 018 FEM

spring activated – electromagnetically released

Brake Caliper EV 018 FEM

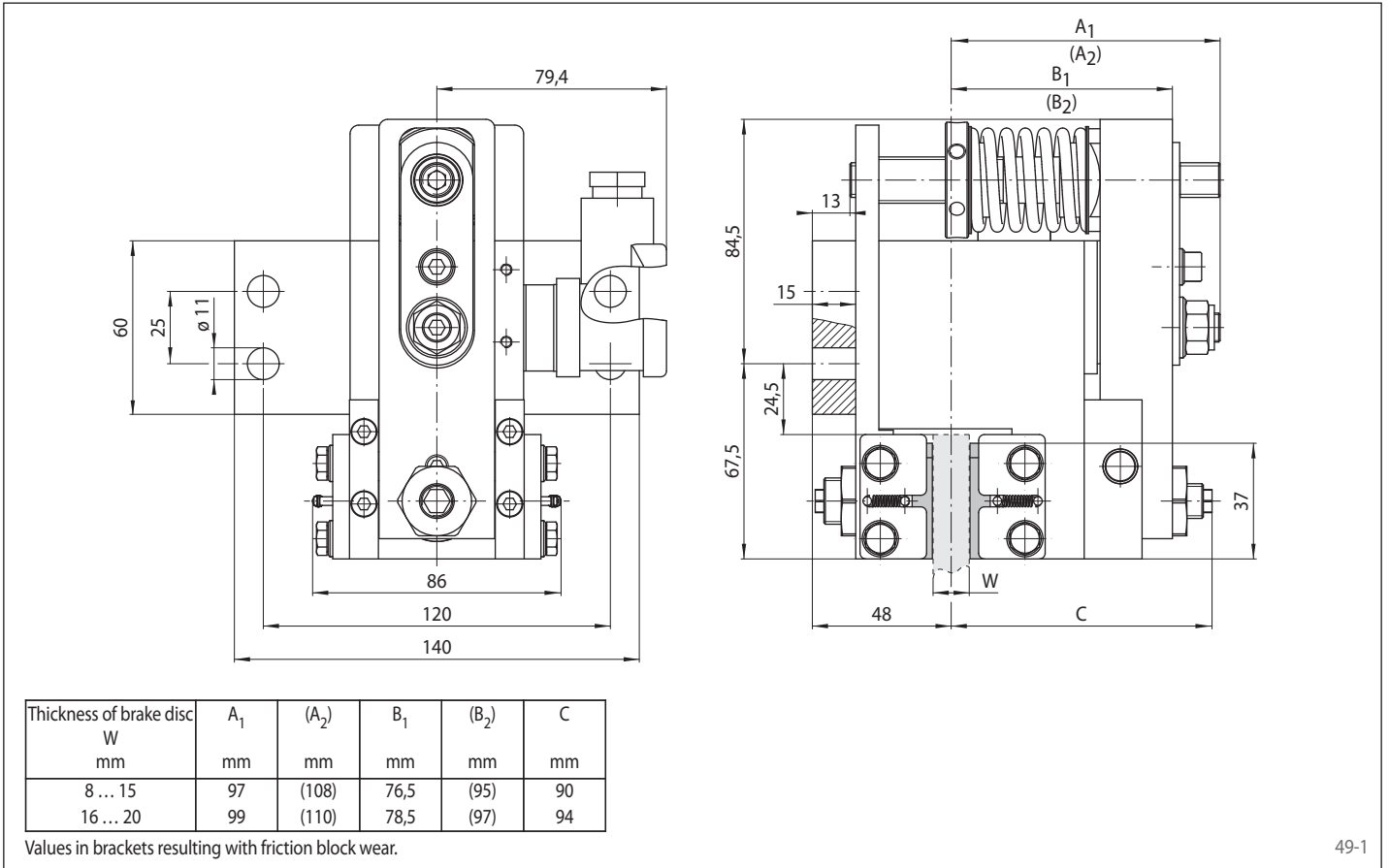

49-1

Brake Caliper EH 018 FEM

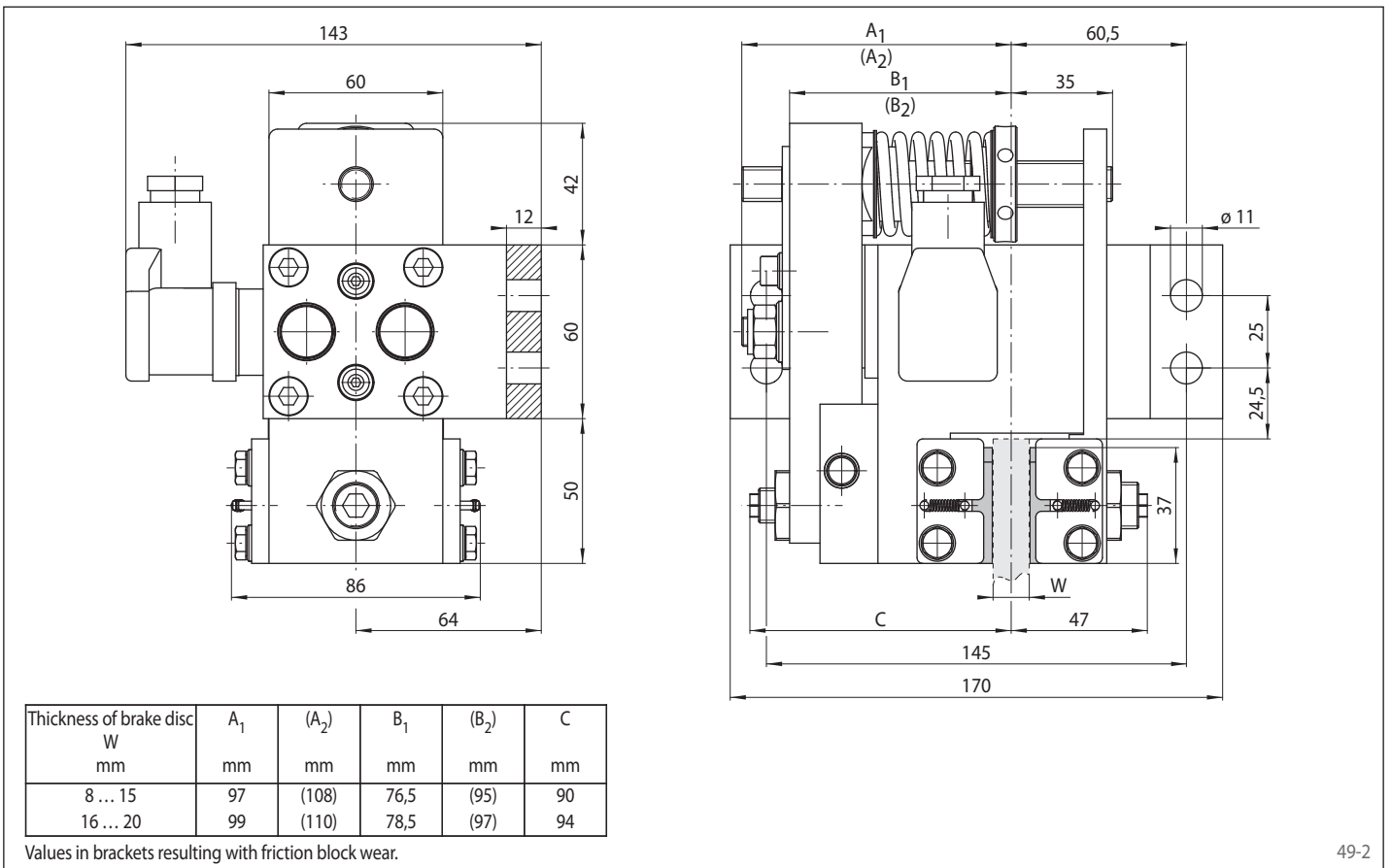

49-2