

# Brake Caliper HW 063 HFA

hydraulically activated – spring released

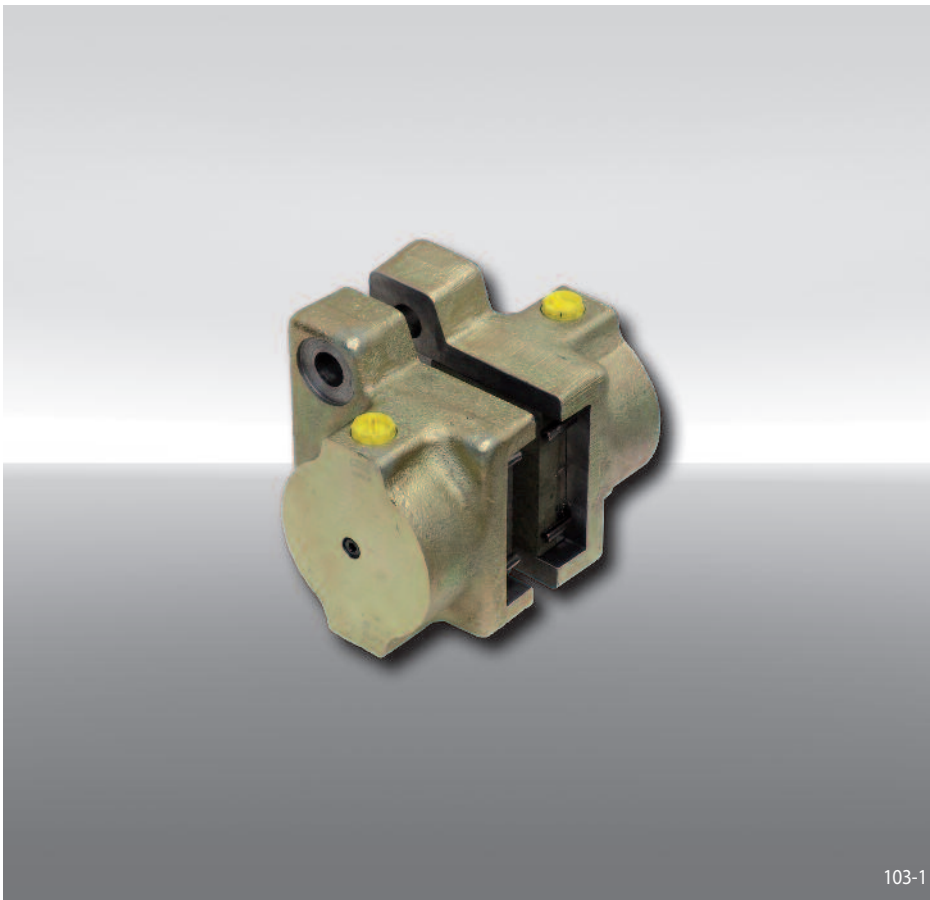

## Features

Features	Code
Brake Caliper	H
Standard	W
With piston diameter 63 mm	063
Hydraulically activated	H
Spring released	F
Automatic adjustment to accommodate friction block wear	A
Max. clamping force 28 kN	028

## Example for ordering

Brake Caliper HW 063 HFA,  
max. clamping force 28 kN:

HW 063 HFA - 028

## Technical Data

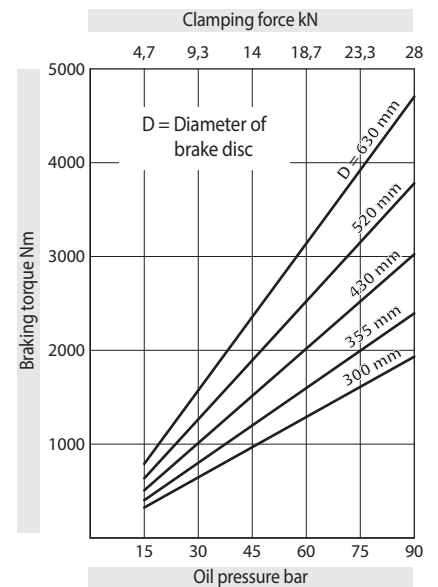

The braking torques shown in the diagram are based on a theoretical friction coefficient of 0,3.

- Oil pressure: min. 5 bar max. 90 bar
- Oil volume: max. 78 cm<sup>3</sup>
- Weight: 8 kg

## Other features

- The thickness of the customer connecting part results from the thickness of the brake disc W plus 3 mm

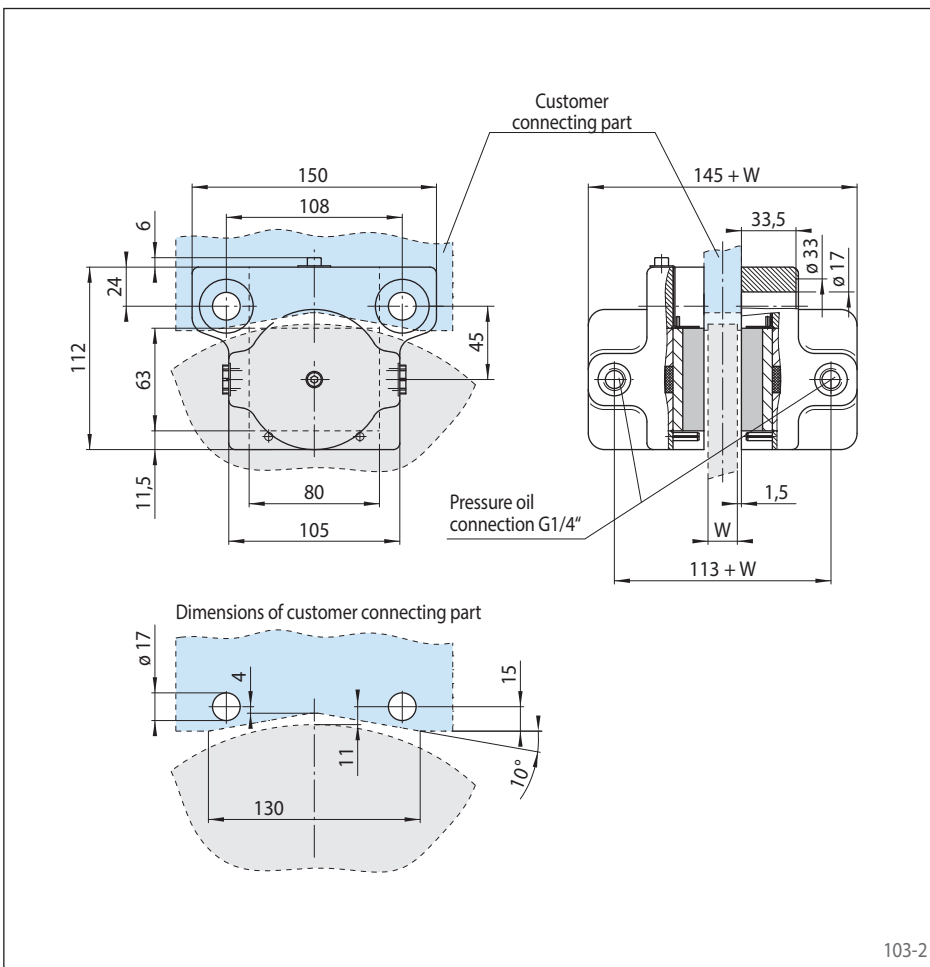

103-1

103-2