

Clamping Unit KEFP

spring activated – pneumatically released

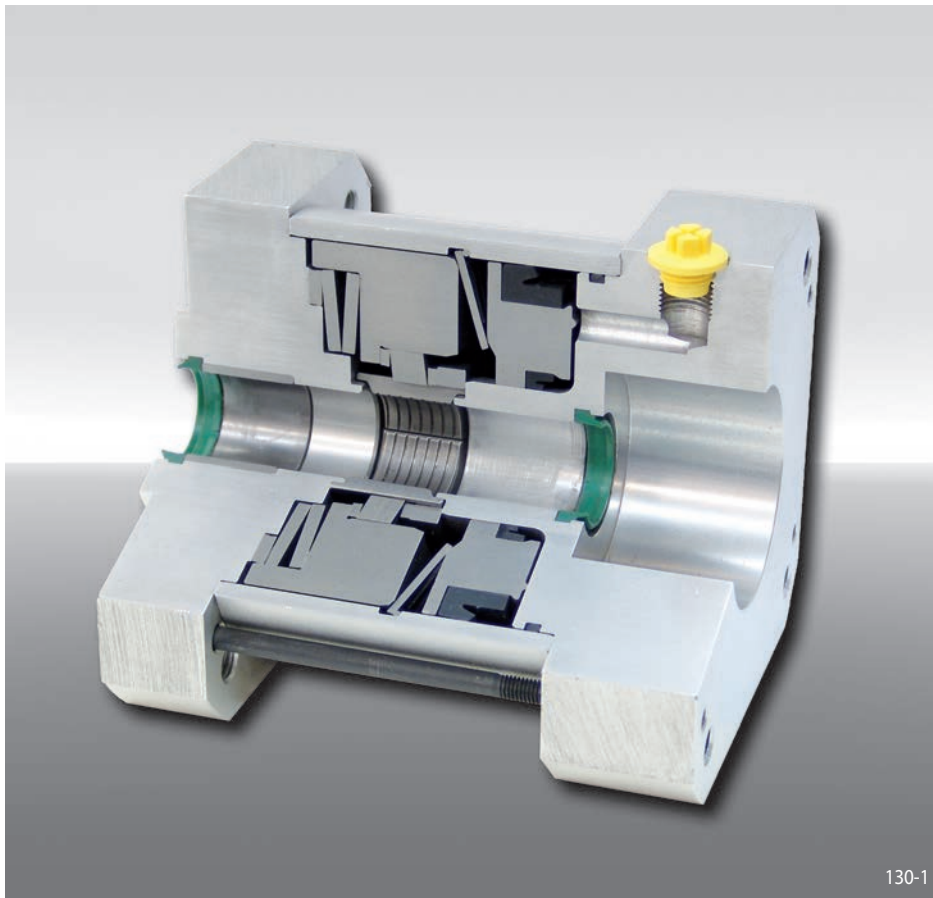

Features

- For continuous piston rod clamping
- Spring activated, pneumatically released
- Connection dimensions compatible with pneumatic cylinders according to ISO
- Holding forces transmissible in both directions of movement
- No application of force (lifting) to the piston rod required for release

Description

The Clamping Unit KEFP clamps and holds pneumatic cylinder piston rods with a calculated clamping force in both directions of movement. The clamping force is applied by

disc springs. Clamping force is released by pneumatic pressure.

The Clamping Units can be bolted directly to any cylinder of the ISO series or attached to other machine components with a connection flange provided by the customer.

Operation

Pneumatic pressure is applied to the Clamping Unit during the working stroke of the pneumatic cylinder. This pressure is transmitted by the piston via the lever spring to the mount and presses the disc springs together. The lever spring translates the pressure into a clamping force. In this position, the clamping discs are free of axial tension and thus allow the piston rod to move freely.

When the pressure on the Clamping Unit is removed, the force of the springs work fully onto the piston and therefore also on to the disc pack. The clamping discs translate the axial spring pressure into a radial force applied to the slotted clamping sleeve that is equal to at least five times the axial pressure. The clamping sleeve transmits the radial clamping forces to the piston rod, thereby holding the piston rod firmly in place.

Each time the pressure falls - even when this was not planned - the Clamping Unit will respond immediately.

Application

The Clamping Unit secures the piston rod with precision against unintentional axial movements.

For example, on machines with cylinders or linear motors a certain position can be driven in one continuous movement. With the Clamping Unit this position can then be held mechanically with accuracy.

The accuracy of the safety Clamping Unit is independent of the size and the direction of the force on the piston rod up to the maximum holding force indicated. No movement of the piston rod is required for the holding force to become effective; the clamping force is effective immediately and does not depend on outside forces.

Clamping Unit KEFP

spring activated – pneumatically released

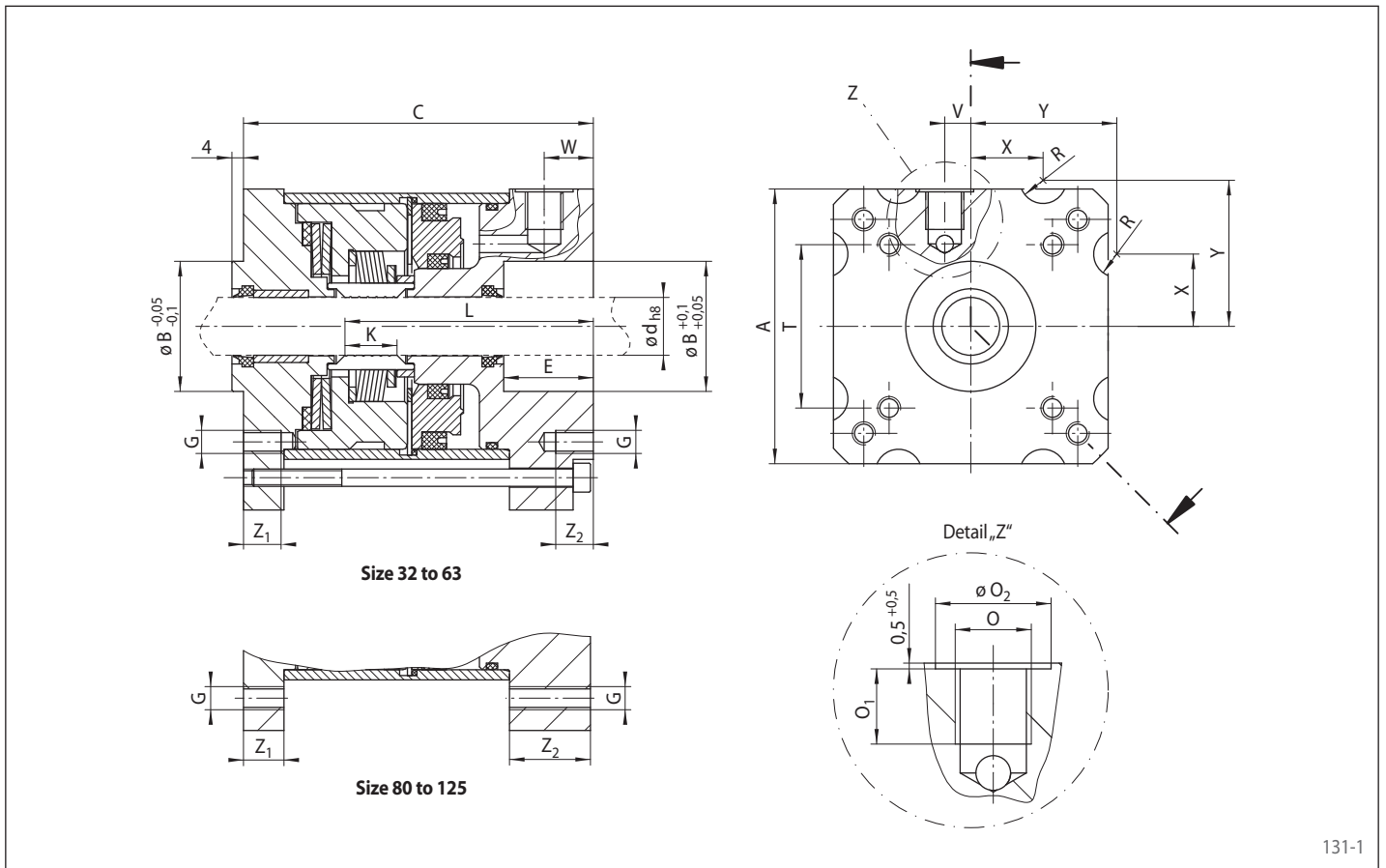

Cylinder- ø	Piston rod- ø d	Holding force $F_H^{1)}$	A	B	C	E	G	K	L	O	O ₁	O ₂	R ²⁾	T	V	W	X ²⁾	Y ²⁾	Z ₁	Z ₂	Air vol. per activation	Weight	Article number
mm	mm	N	mm	mm	mm	mm	mm	mm	mm	mm	mm	mm	mm	mm	mm	mm	mm	mm	mm	mm	cm ³	kg	
32	12	650	60	30	82	22	M 6	10,2	56,7	G1/8	19,5	16	5,5	32,5	7,5	14,0	16	32,0	10,0	10,0	5,5	0,85	4133-037953
40	16	1000	70	35	95	24	M 6	10,2	59,7	G1/8	10,5	16	7,0	38,0	0	15,5	18	36,5	13,0	13,0	5,5	1,10	4133-037954
50	20	1600	75	40	112	30	M 8	14,0	76,0	G1/4	12,5	20	-	46,5	12,0	22,9	-	-	13,0	13,0	13,5	1,50	4133-037952
63	20	2500	95	45	120	30	M 8	18,0	84,9	G1/4	14,0	20	8,0	56,5	0	15,0	25	50,5	14,0	13,0	27,0	3,20	4133-052952
80	25	4000	95	45	140	36	M 10	21,0	92,4	G1/4	14,0	20	-	72,0	0	21,0	-	-	28,0	34,0	27,0	3,50	4133-052953
100	25	6300	120	55	150	40	M 10	20,5	101,3	G1/4	14,0	20	-	89,0	0	21,0	-	-	28,0	37,0	59,0	5,80	4133-052954
125	32	9800	150	60	178	43	M 12	25,0	109,5	G1/4	14,0	20	-	110,0	0	25,0	-	-	42,5	41,5	85,0	10,90	4133-057951

¹⁾ Please note recommendations on page 132.

²⁾ The dimensions R, X and Y are valid only for the flange on the right side.
Release pressure: min. 4 bar, max. 8 bar

Release pressure

The release pressure of the spring activated pneumatically released Clamping Unit KEFP is min. 5 bar and max. 8 bar