

Installation and Operating Instructions for Brake Caliper DV and DH 035 PFM

E 09.746 e



RINGSPANN GmbH

Schaberweg 30-34
61348 Bad Homburg
Germany

Telephone +49 6172 275-0
Telefax +49 6172 275-275

www.ringspann.com
mailbox@ringspann.com

RINGSPANN	Installation and Operating Instructions for Brake Caliper DV and DH 035 PFM, pneumatically activated – spring released	E 09.746 e			
issue: 11.02.2014	Version : 1	drawn.: Su	checked.: Su	pages: 11	page: 2

Important

Please read these instructions carefully before installing and operating the product. Your particular attention is drawn to the notes on safety.

These installation and operating instructions are valid on condition that the product meets the selection criteria for its proper use. Selection and design of the product is not the subject of these installation and operating instructions.

Disregarding or misinterpreting these installation and operating instructions invalidates any product liability or warranty by RINGSPANN; the same applies if the product is taken apart or changed.

These installation and operating instructions should be kept in a safe place and should accompany the product if it is passed on to others – either on its own or as part of a machine – to make it accessible to the user.

Safety Notice

- Installation and operation of this product should only be carried out by skilled personnel.
- Repairs may only be carried out by the manufacturer or accredited RINGSPANN agents.
- If a malfunction is indicated, the product or the machine into which it is installed, should be stopped immediately and either RINGSPANN or an accredited RINGSPANN agent should be informed.
- Switch off the power supply before commencing work on electrical components.
- Rotating machine elements must be protected by the purchaser to prevent accidental contact.
- Supplies abroad are subject to the safety laws prevailing in those countries.

RINGSPANN	Installation and Operating Instructions for Brake Caliper DV and DH 035 PFM, pneumatically activated – spring released			E 09.746 e	
issue: 11.02.2014	Version : 1	drawn.: Su	checked.: Su	pages: 11	page: 3

Contents

1 General remarks

- 1.1 General safety instructions
- 1.2 Special safety instructions

2 Configuration and function

- 2.1 Function
- 2.2 Markings
- 2.3 Drawing and parts list

3 Proper use / specified purpose

4 Improper use

5 Condition upon delivery

6 Handling and storage

7 Technical requirements for safe operation

8 Installing the RINGSPANN brake caliper

- 8.1 General instructions for assembly and installation
- 8.2 Installation
- 8.3 Setting the gap between the brake pad and brake disc

9 Commissioning

- 9.1 Running in

10 Maintenance and repairs

- 10.1 General maintenance
- 10.2 Permissible brake pad wear and brake pad replacement
- 10.3 Braking stroke adjustment
- 10.4 Disassembly and replacement of consumable parts in the pressure cylinder

1. General remarks

The DV and DH 035 PFM brake calipers are machine components use to achieve safe and reliable braking of accelerated masses. Combined with a brake disc, the caliper forms a complete brake capable of securing machines and machine systems effectively.

By virtue of its universal design concept, it performs the following functions:

- As a holding/parking brake, it prevents inadvertent activation of an idle shaft.
- As a stopping brake, it quickly brings a rotating shaft to a standstill in the event of power failures or emergency system shut-downs, for example.
- As a control brake, it ensures adherence to a specific material traction force.

1.1 General safety instructions

Please read these installation and operating instructions carefully before installing and operating the brake caliper. Please refer also to the drawings in the various sections.

Switch off the drive unit before performing work on the brake.

RINGSPANN	Installation and Operating Instructions for Brake Caliper DV and DH 035 PFM, pneumatically activated – spring released			E 09.746 e	
issue: 11.02.2014	Version : 1	drawn.: Su	checked.: Su	pages: 11	page: 4

1.2 Special safety instructions



Danger to life and limb!

It is essential to secure the entire drive train against inadvertent starts during brake installation and maintenance. Rotating components can cause severe injuries.

Therefore, rotating components (e.g. brake disc) must be secured by the operator to prevent accidental contact.

2. Configuration and function

2.1 Function

Braking force is generated by pneumatic pressure. The brake caliper is released by spring force.

2.2 Markings

These installation and operating instructions apply to:

- models DV and DH 035 PFM, right-mounted brake chamber, see Figs. 2.1+ 2.2 in Section 2.3.
- model DH 035 PFM, left-mounted brake chamber.
- mounting on brake discs with thickness of 12.5; 25; 30 and 40 mm.
- various types of brake pads, including e.g. pads with cable for wear monitoring, higher glide speed, double friction surface and/or special friction pad materials.

An identification plate with a 16-digit part number is affixed to the caliper. The precise design of the brake caliper is defined by this part number only.

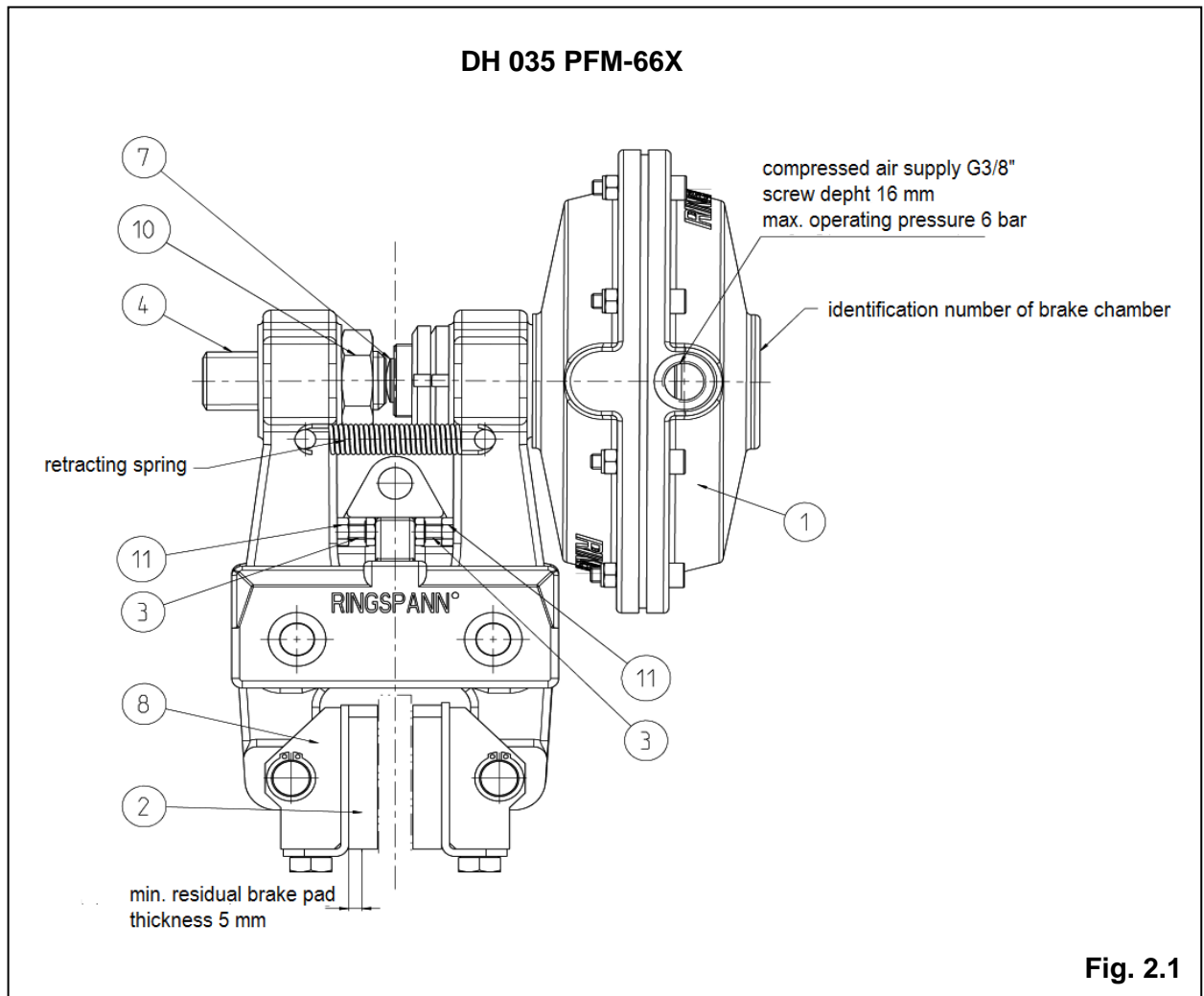
2.3 Drawing and parts list

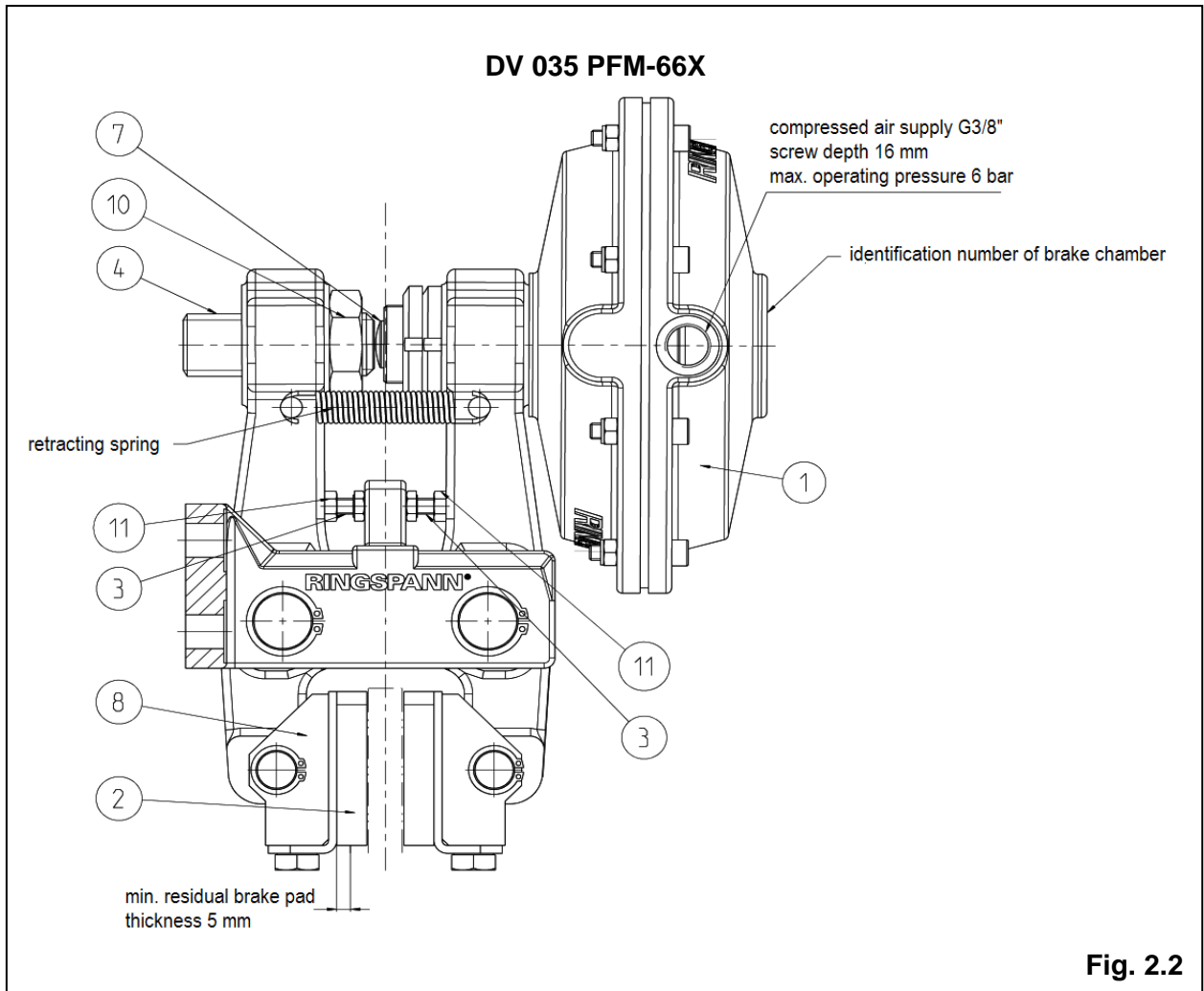

Fig. 2.2

Spare parts list:

Part	Nomenclature	Quantity	Part number
1	Brake chamber Z660	1	3514-190110-000000
	Brake chamber Z661	1	3514-190111-000000
2	Brake pad, standard	2	2472-035013-A00101*
	Brake pad for holding applications	2	2472-035013-A00102*

*) Part number for 1 brake pad

3. Proper use / specific purpose

The brake caliper may be used only in systems with max. 6 bar of pneumatic pressure and in accordance with the technical specifications.

The brake saddle is designed for use as a holding/parking brake, a stopping brake and/or a control brake. Other uses are improper and incompatible with the specified purpose. RINGSPANN assumes no liability for damages resulting from improper use. The risk is assumed by the user alone.

RINGSPANN	Installation and Operating Instructions for Brake Caliper DV and DH 035 PFM, pneumatically activated – spring released			E 09.746 e	
issue: 11.02.2014	Version : 1	drawn.: Su	checked.: Su	pages: 11	page: 7

4. Improper use

Operating the brake caliper under higher pressure than that specified in the technical specifications or with other media is prohibited. Unauthorized constructive modifications of the brake caliper are similarly prohibited. RINGSPANN assumes no liability for damages resulting from improper use. The risk is assumed by the user alone.

5. Condition upon delivery

The brake caliper is adjusted for the brake disc thickness specified in the order with a gap of 0.5 mm between the brake disc and the brake pads on each side.

6. Handling and storage

The brake is delivered with anti-corrosion protection and can be stored in an enclosed, dry space for up to 12 months. It is important to prevent condensation from forming. Moist storage areas are unsuitable. Brakes stored for longer than 12 months must be activated at least once in order to prevent seal adhesion.

7. Technical requirements for safe, reliable operation

The brake caliper should be mounted to stable, vibration-free machine components in order to ensure noise- and squeak-free braking.

8. Installing the RINGSPANN brake caliper

8.1 General instructions for assembly and installation

Before installing the brake saddle, the brake disc must be cleaned with alcohol, e.g. ethyl or isopropyl alcohol or a water-based surfactant solution (soapy water, etc.).

When cleaning the brake disc with a thinner, acetone or a brake cleaning agent, it is important to ensure that neither these cleaners nor any cleaner residues come in contact with the brake pads. This is especially important in the case of brakes used only as parking brakes, as no dynamic braking operations take place during which thinner residues would be rubbed off the brake disc.



Please note!

Oil and rustproofing residues reduce the friction coefficient and thus the transmissible braking torque substantially.

8.2 Installation



Please note!

When mounting the brake caliper can not the brake chamber filled with compressed air be.

During installation, it is essential to ensure that brake pads are centred and in full contact with the brake disc (the midlines of the brake levers must point to the centre of the brake disc). Maximum permissible lateral brake disc wobble is 0.2 mm. Greater wobble may cause rattling and shaking of the brake unit.

RINGSPANN	Installation and Operating Instructions for Brake Caliper DV and DH 035 PFM, pneumatically activated – spring released			E 09.746 e	
issue: 11.02.2014	Version : 1	drawn.: Su	checked.: Su	pages: 11	page: 8

The brake disc is mounted to the machine component with:

4 M12 screws (Model DV 035) or.

3 M12 screws (Model DH 035)

strength class 8.8. Screws must be tightened with a torque spanner (tightening torque 84 Nm).

Check the following connections for tightness:

- brake caliper to machine component
- brake chamber to brake calliper lever arm
- support bolts on the brake caliper lever arm

Check the following for proper seal:

- brake chamber
- hose connection



Please note!

The pressure cylinder has a G 3/8" (Whitworth pipe thread DIN ISO 228-1) compressed air connection. The compressed air connection must be effected with a flexible hose with a minimum diameter of 6 mm in order to prevent the impairment of pressure cylinder movement during operation. Operating pressure may range from 0.5 to 6 bar, depending on braking torque; maximum operating pressure 6 bar.

Compressed air pressure may not be applied until the brake caliper has been mounted to the brake disc.

The pressure cylinder can be operated with oiled or unoled compressed air. Compressed air must be filtered, dried and dehydrated (solid material class 5 – impurities larger than 40 µm must be eliminated with the aid of suitable filters – pressure dew point +2°C). When using unoled compressed air, please ensure that the compressed air contains on ozone, as ozone will cause more rapid aging of the diaphragm.

Max. air volume per switching operation is 280 cm³.

The following oils are recommended for use in the maintenance units when oiled compressed air is used:

<u>Suitable oils</u>	<u>Viscosity at 20° C (mm²/s)</u>
Avia Avilub RSL 3	34
BP Energol HLP 40	27
ESSO Spinesso 34	23
Shell Tellus Öl C 10	22
Mobil VAC HLP 9	25,2

Air volume: At full piston stroke, (maximum brake pad wear and no stroke adjustment via the support bolts) the max. air volume is 450 cm³ / stroke.

In new condition (no brake pad wear) approx. 215 cm³ / stroke

RINGSPANN	Installation and Operating Instructions for Brake Caliper DV and DH 035 PFM, pneumatically activated – spring released			E 09.746 e	
	issue: 11.02.2014	Version : 1	drawn.: Su	checked.: Su	pages: 11 page: 9

8.3 Setting the gap between the brake pads and the brake disc



Please note!

No pneumatic pressure may be applied by the pressure cylinder to the brake caliper during adjustment of the gap between the brake pads and the brake disc.

The brake caliper is set by the manufacturer to the required gap of brake disc thickness + 2 x 0.5 mm (example: brake pad thickness 12.5 mm and a lateral gap of 0.5 between the brake disc and the brake pads on each side = 13.5 mm). If the gaps on the right and left side of the brake disc is not uniform once the brake calliper has been mounted to the machine component, the gaps must be corrected as follows:

- Turn screw M6 (Figs. 2.1 + 2.2, pos. 3) clockwise (right) to enlarge the corresponding gap.
- Turn screw M6 (Figs. 2.1 + 2.2, pos. 3) counter-clockwise (left) to reduce the corresponding gap.
- Set both lever arms uniformly.



Information!

If the gap does not increase when the screws are turned clockwise, the threaded pin (Figs. 2.1+2.2, pos. 4) is in contact with the pressure cylinder piston (Figs. 2.1+2.2, pos. 7).

To enlarge the gap in this case, you must first loosen the nut (Figs. 2.1+2.2, pos. 10) and then turn the threaded pin back until the distance between the threaded pin and the piston reaches 3-5 mm. Set the gap between the brake pads and the brake disc as desired. Turn the threaded pin until it comes in contact with the piston again, and then turn it back by ¼ revolution (this produces a gap of approx. 0.8 mm between the pin and the piston). Tighten the nut.



Please note!

It is essential to ensure that the brake pads (2) do not rub against the brake disc when the brake is released.

9. Commissioning

9.1 Running in

An optimum braking effect can be achieved only when the brake pads (2) are in full contact with the brake disc and have been heated briefly to approx. 200°C.

Therefore, it is necessary to perform multiple brief braking operations (running in) at low pneumatic pressure (1-2 bar) while the brake disc is rotating.

RINGSPANN	Installation and Operating Instructions for Brake Caliper DV and DH 035 PFM, pneumatically activated – spring released			E 09.746 e	
issue: 11.02.2014	Version : 1	drawn.: Su	checked.: Su	pages: 11	page: 10



Please note!

If the brake cannot be run in, the braking torques specified in our publication No. 46 cannot be achieved. Braking torques may be reduced by as much as 50%..

10. Maintenance and repairs

Depending upon operating parameters, maintenance must be performed on the brake caliper at intervals of between 4 and 12 weeks.

10.1 General maintenance

- Check both brake caliper arms for ease of movement.
- Clean all bearing and glide points
- Oil or grease bearing and glide points.
- Check to ensure that the brake pads do not rub against the brake disc when the brake is released and that the gap is equal on both sides. Adjust the gap as described in Section 5.3 if necessary.



Please note!

Brake pads may not be exposed to contact with lubricants!

- Check the following connections for tightness:
 - brake caliper to machine component
 - brake chamber to brake caliper lever arm
 - brake pads to brake caliper lever arm
- Check the following for proper seal:
 - brake chamber
 - hose connection
(leaks can be detected easily and quickly with a product such as "Güpoflex LECKSUCHER", manufactured by: GÜPO GmbH, 77694 Kehl, Germany telephone +49 07851/4044-45).

10.2 Permissible brake pad wear and brake pad replacement



Please note!

Brake pads may not be worn beyond a residual thickness of 5 mm (Figs. 2.1+2.2). (At this thickness, the maximum possible swivel range of the brake levers is exhausted and no further braking power is available.)
Brake pads must always be replaced in pairs.

RINGSPANN	Installation and Operating Instructions for Brake Caliper DV and DH 035 PFM, pneumatically activated – spring released	E 09.746 e
issue: 11.02.2014	Version : 1	drawn.: Su checked.: Su pages: 11 page: 11



Danger to life and limb!

Brake pads may be replaced only with the machine system is shut down!

Replacing brake pads:

- Before replacing the brake pads, ensure that the mass held by the brake is secured against inadvertent movement, as the brake must be release in order to replace the brake pads (2).
- No pressure may be applied to the brake chamber. The brake must be released.
- Remove the brake pads by removing the two hex screws on the face of the swivel element. Turn the screws (3) into the brake lever. Then turn the threaded pin (4) counter-clockwise with an SW 12 hex socket spanner until the new brake pads can be inserted between the swivel element (8) and the brake disc.
- Fasten the new brake pads by inserting the two hex screws on the face of the swivel element and tightening them by hand.

SW 17 open- or closed-ended spanner are required to tighten and remove the screws. Make sure that there is no gap between the brake pad and the swivel element.

Note: Tighten the screws only partially at first and activate the brake. The brake clamping force causes the brake pads to lie properly against the swivel element. Then tighten the screws to the full tightening torque of 30 Nm (M10-8.8; $\mu = 0.12$).

After replacing the brake pads, the brake gap must be adjusted as described in Section 8.3.

10.3 Braking stroke adjustment

When the friction material is abraded (worn), the gap between the brake disc and the brake pads is enlarged. The required braking stroke increases. The braking stroke can be adjusted as described in Section 8.3 "Setting the gap between the brake pads and the brake disc".



Information!

The braking stroke increases with brake pad wear. Brake engagement time becomes slightly longer.

10.3 Disassembly and replacement of consumable parts in the pressure cylinder

The brake chamber (1) is defective if the piston no longer moves when air pressure to the piston (7) is applied or released or air is released from the spring brake chamber.



Information!

In the interest of safety, the inspection and repair of a defective brake chamber should always be performed at the RINGSPANN plant. If this is not possible due to special circumstance, we request that you consult us before proceeding.