

**Installation and Operating Instruction for
Brake Caliper HW 075 HFK**

E 09.741e

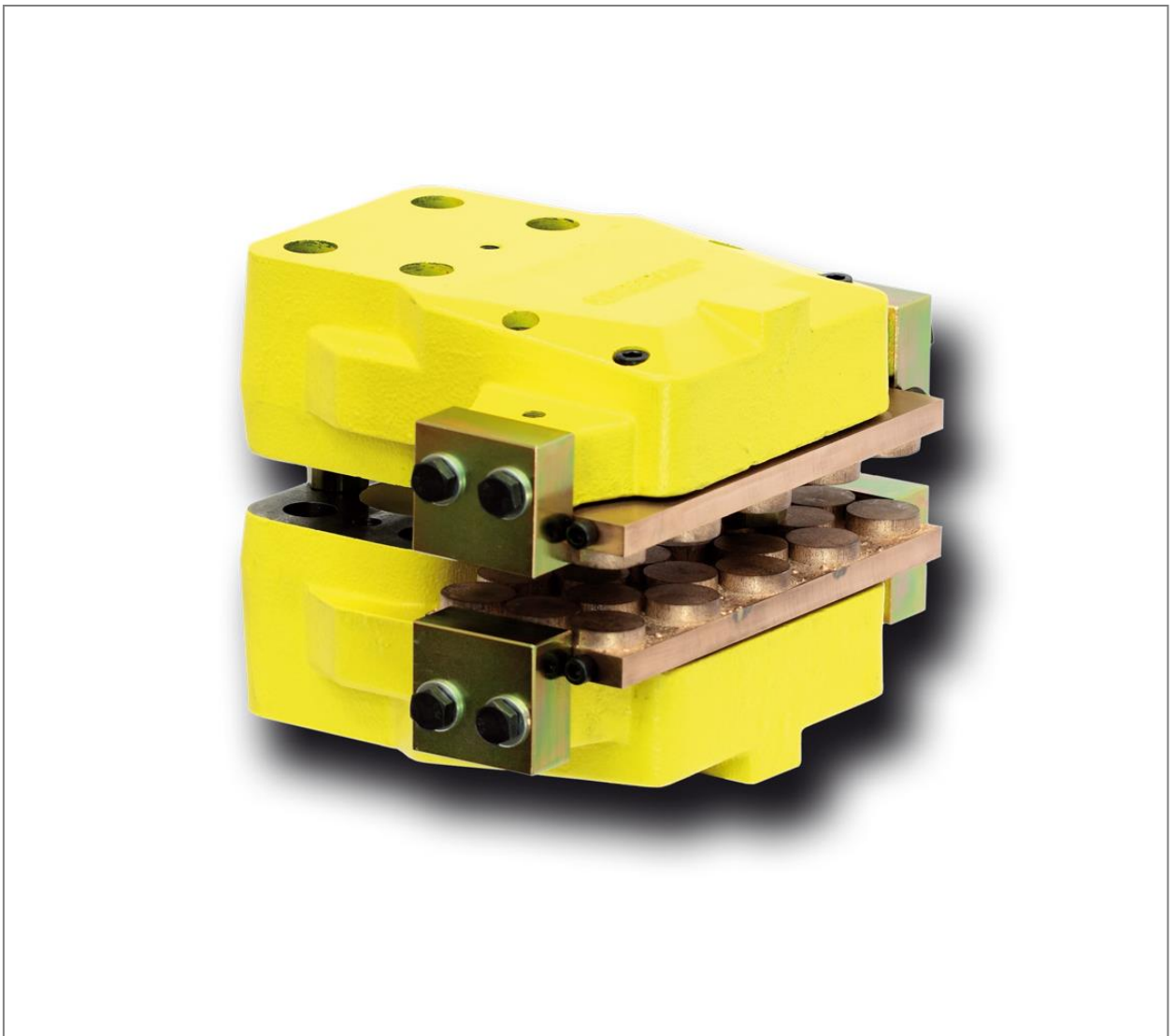

RINGSPANN GmbH

Schaberweg 30-34
61348 Bad Homburg
Germany

Telephone +49 6172 275-0
Telefax +49 6172 275-275

www.ringspann.com
mailbox@ringspann.com

RINGSPANN	Installation and Operating Instructions for Brake Caliper HW 075 HFK hydraulic activated – spring released			E 09.741e	
Date: 23.01.2014	Issue : 4	draw:Su	checked: Ei	Pages: 16	Page: 2

IMPORTANT

Please read these instructions carefully before installing and operating the product. Your particular attention is drawn to the notes on safety.

These installation and operating instructions are valid on condition that the product meets the selection criteria for its proper use. Selection and design of the product is not the subject of these installation and operating instructions.

Disregarding or misinterpreting these installation and operating instructions invalidates any product liability or warranty by RINGSPANN; the same applies if the product is taken apart or changed.

These installation and operating instructions should be kept in a safe place and should accompany the product if it is passed on to others – either on its own or as part of a machine – to make it accessible to the user.

SAFETY NOTICE

- Installation and operation of this product should only be carried out by skilled personnel.
- Repairs may only be carried out by the manufacturer or accredited RINGSPANN agents.
- If a malfunction is indicated, the product or the machine into which it is installed, should be stopped immediately and either RINGSPANN or an accredited RINGSPANN agent should be informed.
- Switch off the power supply before commencing work on electrical components.
- Rotating machine elements must be protected by the purchaser to prevent accidental contact.
- Supplies abroad are subject to the safety laws prevailing in those countries.

RINGSPANN	Installation and Operating Instructions for Brake Caliper HW 075 HFK hydraulic activated – spring released			E 09.741e	
	Date: 23.01.2014	Issue : 4	draw:Su	checked: Ei	Pages: 16 Page: 3

Contents

1. General remarks

- 1.1 General safety instructions
- 1.2 Special safety instructions

2. Configuration and function / Parts list

- 2.1 Function
- 2.2 Markings
- 2.3 Drawing and parts list

3. Proper use / specified purpose

4. Improper use

5. Condition on delivery

6. Handling and storage

7. Technical requirements for safe and reliable operation

8. Installation of the RINGSPANN brake caliper

- 8.1 General instructions for assembly and installation
- 8.2 Assembly and installation
- 8.3 Assembling the bolt connection and releasing the brake
- 8.4 Connecting the signal cable (optional for organic brake pads)
- 8.5 Dismantling the brake

9. Commissioning

10. Lubrication

11. Maintenance

- 11.1 General maintenance
- 11.2 Permissible brake pad wear and replacement of the brake pads
- 11.3 Replacement of gasket, wiper and piston seal

12. Accessories: Inductive proximity switch

- 12.1. Installing and connecting the inductive proximity switch

RINGSPANN	Installation and Operating Instructions for Brake Caliper HW 075 HFK hydraulic activated – spring released			E 09.741e	
	Date: 23.01.2014	Issue : 4	draw:Su	checked: Ei	Pages: 16 Page: 4

1. General remarks

1.1 General safety instructions

Please read these installation and operating instructions carefully before installing and operating the brake caliper. Please refer also to the drawings in the various sections.

Safety must be given the highest priority during all work performed on the brake.

Switch off the drive unit before performing work on the brake.

Rotating components (e.g. brake disc) must be secured by the operator to prevent accidental contact.

1.2 Special safety instructions



Danger to life and limb!

It is essential to secure the entire drive train against inadvertent starts during brake installation and maintenance. Rotating components can cause severe injuries.

Therefore, rotating components (e.g. brake disc) must be secured by the operator to prevent accidental contact.

2. Configuration and function / Parts list

2.1 Function

The brake caliper HW 075 HFK is a machine component used for the purpose of braking accelerated masses safely and reliably. The combination of brake caliper and brake disc provides a complete brake unit capable of securing machines and equipment system effectively. Thanks to its universal design, it can perform the following functions:

- As a holding or parking brake, it prevents the unintended start of a stationary shaft.
- As a stopping brake, it brings a rotating shaft to a complete standstill.
- As a control brake, it effectively maintains material tension

Braking force is generated by hydraulic pressure. The brake caliper is released by spring force.

Braking force is generated with the aid of hydraulic fluid. The brake pads open up to a residual pressure of < 0,3 bar.

2.2 Markings

These installation and operating instructions apply to:

- model HW 075 HFK
- for models with and without inductive proximity switches
- for various brake pad materials as well as brake pads with wear alarm cables.

Please refer to the drawings in the individual sections.

RINGSPANN	Installation and Operating Instructions for Brake Caliper HW 075 HFK hydraulic activated – spring released			E 09.741e	
	Date: 23.01.2014	Issue : 4	draw:Su	checked: Ei	Pages: 16 Page: 5

2.3 Drawing and Parts List

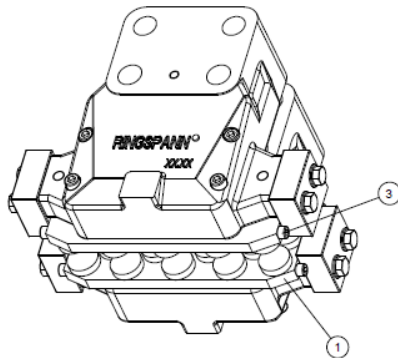

Fig. 2.1

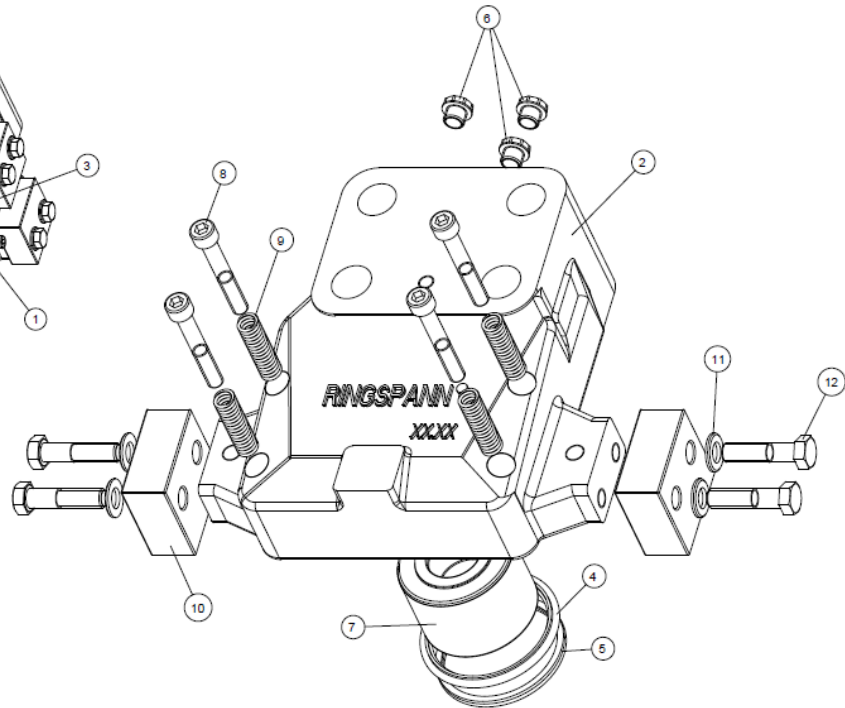

Fig. 2.2

Part	Nomenclature	Quantity	Part number
1	Brake pad HW(S) 075 Sintermet. MD 550	2	2472-975000-A00106
2	Brake caliper housing 075	2	2478-260010-000000
3	Hexagonal socket head cap screw M8x12 DIN EN ISO 4762-10.9	8	5001-008004-000000
4	Turcon-Stepseal 2K RSK300750-T46N	2	5148-075402-000000
5	Turcon-Excluder 2 WE3200750-T46V	2	5148-075411-000000
6	Stopper plug R ¼" KAPSTO GPN 700	6	5025-013205-000000
7	Piston to HW 075 HFK	2	2478-075905-000000
8	Hexagonal socket head cap screw M10x70 DIN EN ISO 4762-A2-70	8	5001-010627-000000
9	Pressure spring RDF-2199	8	2707-015004-000000
10	Holding plate	4	2769-066002-000000
11	Disc B13 DIN EN ISO 7089-ST galvanized	8	5105-013201-000000
12	Hexagonal screw M12x50 DIN EN ISO 4014-10.9	8	5018-012102-000000

3. Proper use / specified purpose

The brake caliper may be used only in systems with a maximum hydraulic pressure of 125 bar and in accordance with the technical specification.

RINGSPANN	Installation and Operating Instructions for Brake Caliper HW 075 HFK hydraulic activated – spring released			E 09.741e	
	Date: 23.01.2014	Issue : 4	draw:Su	checked: Ei	Pages: 16 Page: 6

The brake caliper is designed for use as a holding/parking brake, a stopping brake and/or a control brake.

Other uses are improper and incompatible with the specified purpose. RINGSPANN assumes no liability for damages resulting from improper use. The risk is assumed by the user alone.

4. Improper use

Operating the brake caliper under higher pressure than that specified in the technical specifications or with other media is prohibited. Unauthorized constructive modifications of the brake caliper are similarly prohibited. RINGSPANN assumes no liability for damages resulting from improper use. The risk is assumed by the user alone

5. Condition on delivery

The brake caliper is inspected prior to delivery at a pressure of 160 bar. The unit is delivered as two brake caliper-halves.

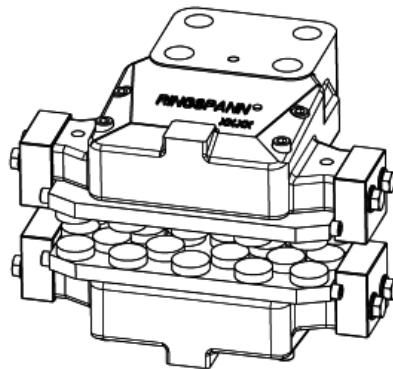

Fig. 5.1

6. Handling and storage

Each brake caliper-half weighs approximately 30 kg. An M10 threaded transport bore is provided to facilitate handling.

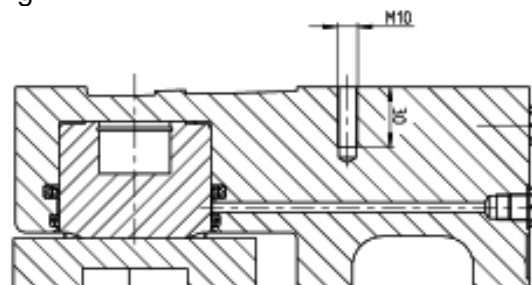

Fig. 6.1

The brake is delivered with anti-corrosion protection and can be stored in an enclosed, dry space for up to 12 months. It is important to prevent condensation from forming. Humid storage areas are unsuitable. Brakes stored for longer than 12 months must be activated at least once in order to prevent seal adhesion. Brakes must also be activated after every transport.

RINGSPANN	Installation and Operating Instructions for Brake Caliper HW 075 HFK hydraulic activated – spring released			E 09.741e	
	Date: 23.01.2014	Issue : 4	draw:Su	checked: Ei	Pages: 16 Page: 7

7. Technical requirements for safe and reliable operation

To ensure low-noise braking, the brake caliper should be mounted on stable, low-vibration machine components.

8. Installation of the RINGSPANN brake caliper

8.1 General instructions for assembly and installation

Before installing the brake, the brake disc must be cleaned with alcohol, e.g. ethyl or isopropyl alcohol or a water-based surfactant solution (soapy water, etc.) and then rubbed dry with a clean cloth.

When cleaning the brake disc with a thinner, acetone or a brake cleaning agent, it is important to ensure that neither these cleaners nor any cleaner residues come in contact with the brake pads. This is especially important in the case of brakes used only as parking brakes, as no dynamic braking operations take place during which thinner residues would be rubbed off the brake disc.



Caution!

Oil and rust-proofing-agent residues reduced friction coefficient and thus diminish transmissible braking torque substantially!

8.2 Assembly and installation



Caution!

The two halves of the brake caliper must not be exposed to hydraulic pressure during assembly/installation.

During installation, it is essential to ensure that brake pads are centred and in full contact with the brake disc. Maximum permissible lateral brake disc wobble is 0.1 mm. Greater wobble may cause rattling and shaking of the brake unit.

The brake caliper is attached with 4 screws M24-12.9, which are lubricated with MoS₂. The recommended tighten torque is 880 Nm. (Screws are not included in the delivery package).

The thickness of the customer's contact component between the two halves of the brake caliper must correspond exactly to the thickness of the brake disc + 3 mm. This provides for a distance of 1.5 mm between the brake disc and the brake pad on each side.

In order to ensure sufficient space for brake pad changes, a gap of at least 260 mm should be left on one side, so that the brake pads can be removed and installed easily.

Prior to installation, check to ensure that the mounting surface is smooth and concentric run between the brake disc and the mounting surface lies within a tolerance of 0.3 mm.

Check to ensure that the maximum permissible angular misalignment of 0.15 mm between the brake disc and the mounting surface is not exceeded.

Check the axial movement of the brake disc. Axial movement must not exceed ± 0.3 mm.



Caution!

Check to ensure that the brake disc rotates freely.

8.3 Assembling the bolt connection and releasing the brake

Connect the pressure and oil drain connecting

The connection is to one of the two pressure oil connections G ¼ in the brake caliper housing 075. The second hole can as vent hole or can be used for pressure transmission to the second brake caliper half. Before to installation of the leak oil line remove the stopper plug (6).

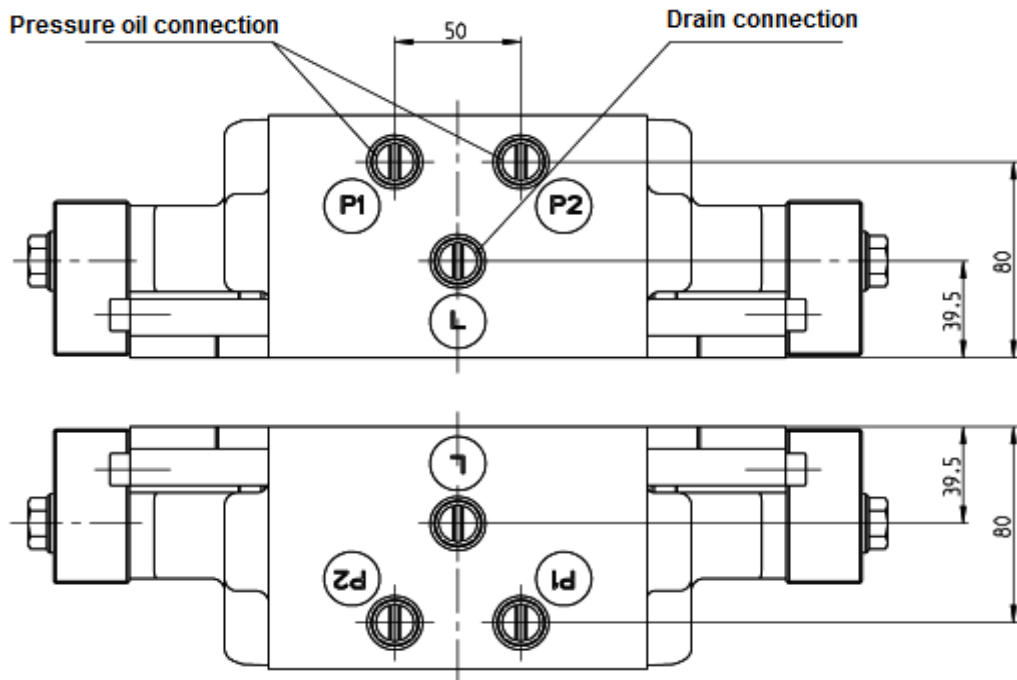

Fig. 8.1

Mounting to each of the vent holes measuring a mini connector or an automatic ventilation system. For this purpose, first remove the screw plug.



Please note!

The venting of the brake should be on the upper pressure connections.

For initial installation, gasket replacement or other work performed on the hydraulic system the hydraulic system must be bled.

If the system is designed for circulation from hydraulic oil, the hydraulic system can be bled by circulating the hydraulic oil.

RINGSPANN	Installation and Operating Instructions for Brake Caliper HW 075 HFK hydraulic activated – spring released			E 09.741e	
	Date: 23.01.2014	Issue : 4	draw:Su	checked: Ei	Pages: 16 Page: 9



Caution!

Oil expelled from the system must be removed completely. Leaks must be repaired immediately.

Check to ensure that screws and other connections are tight:

- brake caliper to machine component.

Check the following for absence of leaks:

- bolt connections and other connections



Caution!

The brake caliper has four hydraulic fluid connections marked P1 and P2, size G ¼ (Whitworth pipe thread DIN ISO 228-1) and four oil drain connections marked L, size G ¼ (Whitworth pipe thread DIN ISO 228-1). The hydraulic system must never be operated at a higher pressure than is specified for the system. The maximum permissible operating pressure is 125 bar.

Oil volume: per 1 mm piston stroke = 9 cm³ per brake caliper (1 caliper = 2 halves)
max. oil volume (at max. brake pad wear) = 57 cm³ per brake caliper.

Alloyed mineral oil, Group HLP as defined in DIN 51525, or API class SC, SD or SE may be used as pressure fluid.



Please note!

The purer the hydraulic fluid, the longer service life of the brake system.



Caution!

It is essential to ensure that the brake pads Pos. 1 do not rub against the brake disc when the brake is released.

RINGSPANN	Installation and Operating Instructions for Brake Caliper HW 075 HFK hydraulic activated – spring released			E 09.741e	
	Date: 23.01.2014	Issue : 4	draw:Su	checked: Ei	Pages: 16 Page: 10

8.4 Connecting the signal cable (optional for organic brake pads)

Connect the signal alarm cable to a 24V control voltage source, e.g. via a signal light. When the maximum permissible brake pad wear thickness is reached, a contact comes established with the neutral conductor and the signal lamp lights up.

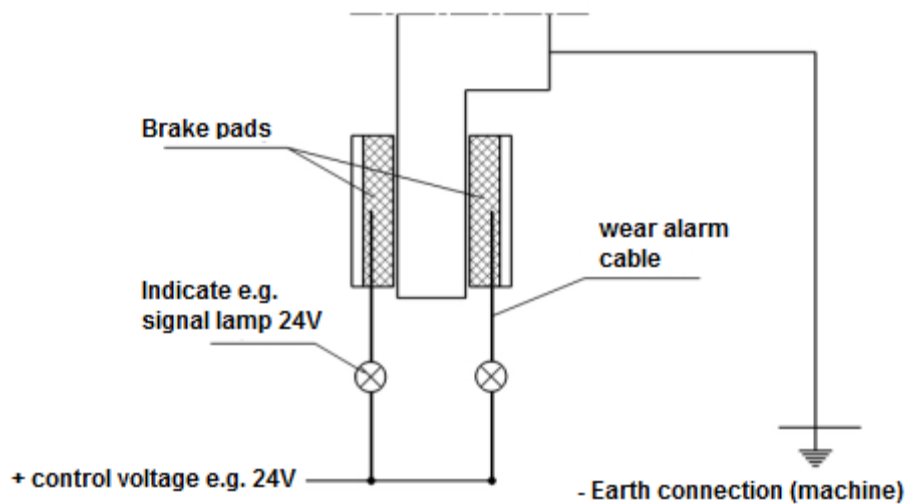

Fig. 8.2

8.5 Dismantling the brake



Danger to life and limb!

When disassembling the brake it is essential to ensure that the entire drive train is secured against inadvertent activation. Rotating components can cause severe injuries. Therefore, rotating components (e.g. brake discs) must be secured by the operator to prevent accidental contact.



Caution!

Ensure that no hydraulic pressure is applied to the brake caliper.

Disconnect the hydraulic lines from the brake caliper-halves. Remove the M24 mounting screws used to attach the brake caliper-halves. The brake caliper can then be removed from the mounting surfaces.

RINGSPANN	Installation and Operating Instructions for Brake Caliper HW 075 HFK hydraulic activated – spring released			E 09.741e	
	Date: 23.01.2014	Issue : 4	draw:Su	checked: Ei	Pages: 16 Page: 11

9. Commissioning

Full-surface contact between the two brake pads (Pos. 1) and the brake disc as well as brief heating of the brake pads to approx. 200°C are required to ensure optimum braking. Therefore, multiple brief braking operations (running in) under low hydraulic pressure must be performed while the brake disc is rotating.



Caution!

If the brake pads cannot be run in, the torques listed in our Publication 46 cannot be achieved. Reductions of up to 50% are possible.

10. Lubrication

Oil or grease all bearing and glide points.



Caution!

Brake pads must not come in contact with lubricants.

11. Maintenance

11.1 General maintenance

Maintenance must be performed on the brake caliper at intervals of between 4 and 12 weeks, depending upon the frequency and duration of operation.

Perform the following checks during every maintenance operation:

- Check brake pads for wear.
- Check the bolt connection between the brake caliper and the machine component and the bolt connection for the holding plates (Pos. 10) for solid compound.
- Check the hydraulic lines and -connections for leaks.
- Check the brake piston gasket system for proper seal by inspecting the oil leak lines. If there is oil in the oil leak lines, the gasket must be replaced
- Observe fluid change intervals! Change mineral oil after every 8.000 hours operation or once per year.



Caution!

Brake pads must not come in contact with lubricants.
Brake pads must not come in contact with mineral oil.

RINGSPANN	Installation and Operating Instructions for Brake Caliper HW 075 HFK hydraulic activated – spring released			E 09.741e	
	Date: 23.01.2014	Issue : 4	draw:Su	checked: Ei	Pages: 16 Page: 12

11.2 Permissible brake pad wear and replacement of the brake pad



Danger to life and limb!

Brake pads may be replaced only when the equipment system and/or the working machine is at a complete standstill!



Caution!

Brake pads must not be worn to a residual thickness of less than 16 mm (mounting plate thickness plus remaining pad material). Brake pads must always be replaced in pairs.

Before replacing the brake pads (Pos. 1), ensure that the mass by the brake is secured to prevent movement, because parts of the brake must be loosened for replacement.

Make sure that no oil pressure acts to the brake caliper; solve one of the two holding plates (10) at each the caliper-halves.

Remove the 4 hex. socket head cap screw M10x70 (Pos.8). Note that the cylinder screws are slightly pre-tensed by the compression springs (Pos. 9). Pull the old brake pads out from the side and push the brake piston (Pos. 7) back into the brake caliper housing (Pos. 2). Inserting the new brake pads. Fix the brake pads with the 4 hex. socket head cap screw M10x70 and the 4 compression springs.

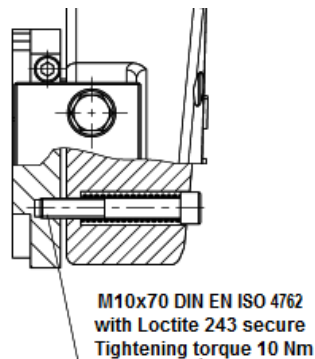

Fig. 11.1

Use Loctite 243 to secure the threads for the screws M10x70 (Pos. 8); tightening torque of the screws is 10 Nm.



Caution!

The threaded bore in the brake pad is a tapped blind hole with a depth of approx. 5 mm. A tightening torque in excess of 10 Nm may damage or destroy the thread!

Attach the holding plate (Pos.10) with the specified tightening torque of 125 Nm.

RINGSPANN	Installation and Operating Instructions for Brake Caliper HW 075 HFK hydraulic activated – spring released			E 09.741e	
	Date: 23.01.2014	Issue : 4	draw:Su	checked: Ei	Pages: 16 Page: 13

11.3 Replacment of gasket, wiper and piston seal



Caution!

Brake pads must not come in contact with mineral oil.



Danger to life and limb!

Gaskets may be replaced only when the equipment system and/or the working machine is at a complete standstill!



Caution!

Ensure that no hydraulic pressure is applied to the brake caliper. Observe the manufacturer's instructions when handling solvents.

Maximum possible cleanliness is essential when working on the hydraulic system. Each part must be cleaned in solvent, dried and stored protected in a dust-free place. Dirt reduces the service life of the gaskets substantially. Check the surfaces of the brake caliper housing and brake pistons for damage. Surface damage can destroy a gasket immediately.

Remove the brake caliper-halves. Remove the 4 hex. socket head cap screw M10x70 (Pos. 8) that keep the friction pads. Note that the cylinder screws are slightly pre-tensed by the compression springs (Pos. 9). Close a pressure oil connection on each of the brake caliper-halves and connect a hydraulic hand pump to the second pressure oil connection. Hold or clamp the brake caliper housing (Pos. 2) firmly in place. Push the brake piston Pos. 7 with the aid of the hand pump out. Make sure that the brake pistons is pressed evenly out of the brake caliper housing (Pos. 2).

Remove the Turcon-Excluder 2 seals (Pos. 5) and then the Turcon-Stepseal 2K (Pos. 4) from the brake caliper housing (Pos. 2).

Prior to assembly and installation, the brake caliper housing should be inspected for damage, cleaned and lubricated.

Install the new seal and the new double wiper in the brake caliper housing. Observe the correct installation position for the seal and the double wiper as shown in Fig 11.2. The incorporation should be occur by hand to ensure that the sealing edge is not damaged. The seal and the doble wiper can be inserted more easily be bending it into a kidney shape and laying it into the groove. Oiling the seal with a light coat of Molycote prior to assembly. Push the piston centric with a press or beat with a plastic hammer into the cylinder bore to the stop point.

Then mount the brake pad as described in Chapter 11.2 ; and the brake saddle to the machine frame as described in Chapter 8 and 9.

RINGSPANN	Installation and Operating Instructions for Brake Caliper HW 075 HFK hydraulic activated – spring released			E 09.741e	
	Date: 23.01.2014	Issue : 4	draw:Su	checked: Ei	Pages: 16 Page: 14

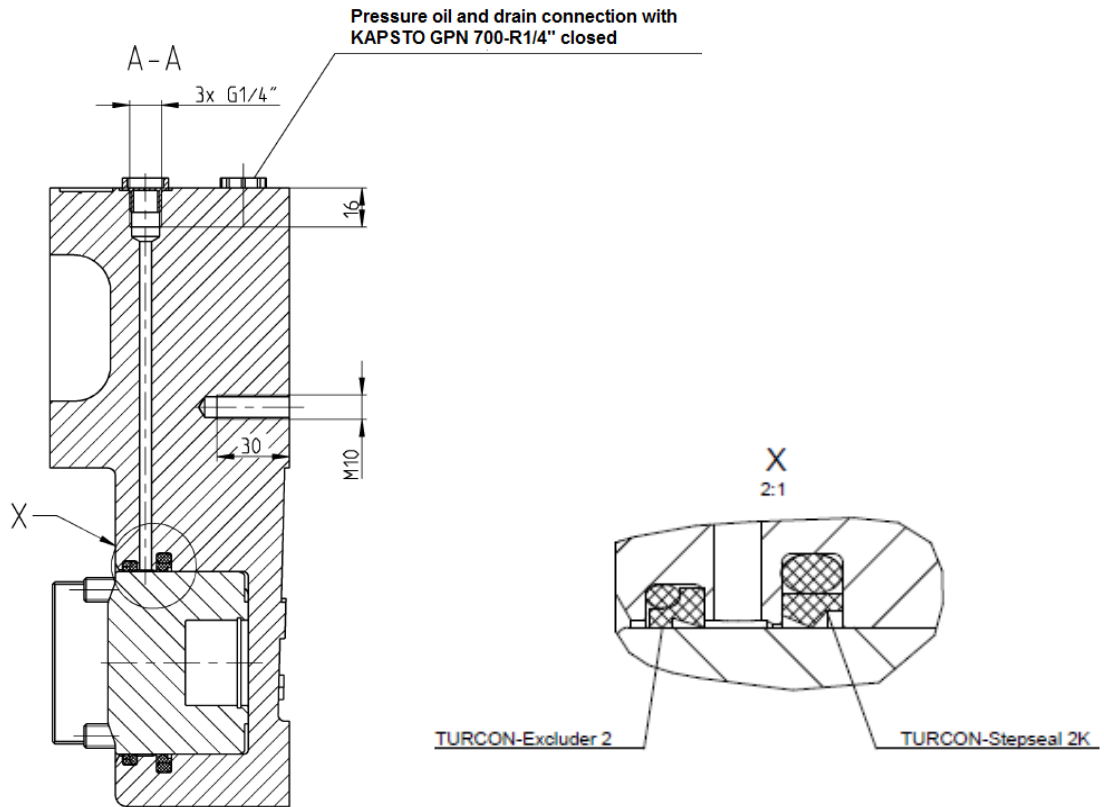

Fig. 11.2

12. Accessories: Inductive proximity switch

12.1. Installing and connecting the inductive proximity switch



Danger to life and limb!

The inductive proximity switch may be installed and/or replaced only when the equipment system and/or working machine is at a complete standstill!

The 3502-112003-B024VG, M12x1, 65 mm inductive proximity switch with stainless steel housing is not delivered pre-mounted.

Two threaded bores (M12x1) are drilled in the brake housing as mounting bores for the inductive proximity switch.

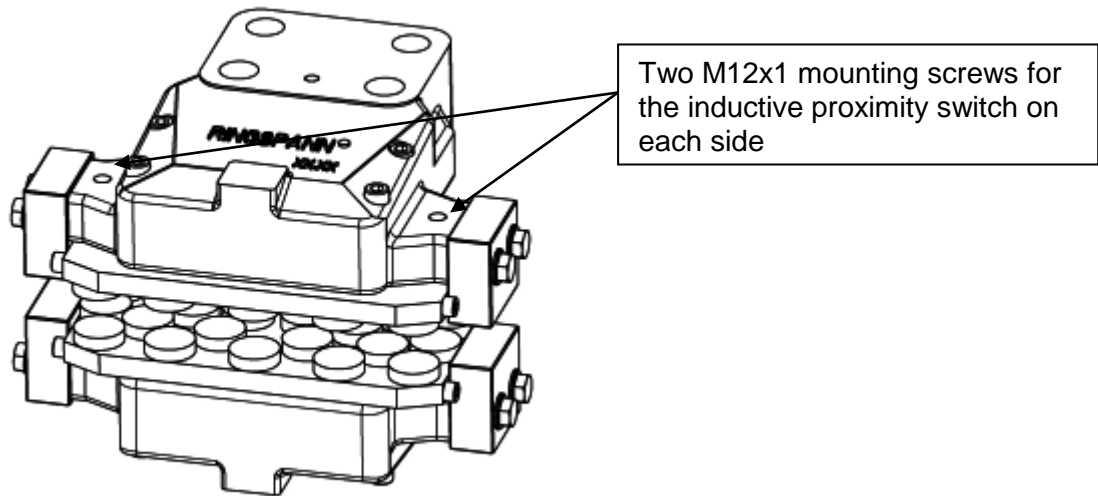

Fig. 12.1

Switching function	: PNP (Closer)	Switching distance	: 2 mm flash
Operating voltage	: 10....30 V DC	max. op. current	: 0...200 mA
No-load current	: < or = 17 mA	Leakage current	: < or = 0,5 mA
Voltage drop	: < or = 3 V	Short-circuit protect	: clocking
Rev. Polarity protec.:	yes	Switch indicator	: multi-hole LED
Temp. Range	: -25 to +70°C	Safety class	: IP 67
Connection	: V1-Connector	Housing	: stainless steel

Circuit diagram of the inductive proximity switch

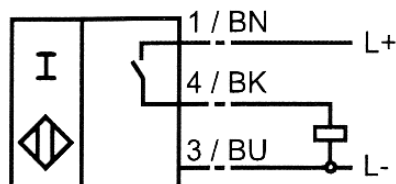

Fig. 12.2



Please note!

The inductive proximity sensor must be positioned in such a way that it is damped in the absence of hydraulic pressure (the LED on the inductive proximity switch glows). When the brake is activated, the brake engages and the inductive proximity sensor moves out of the range of the switch and is no longer damped. The LED on the inductive proximity sensor goes out.

RINGSPANN	Installation and Operating Instructions for Brake Caliper HW 075 HFK hydraulic activated – spring released			E 09.741e	
Date: 23.01.2014	Issue : 4	draw:Su	checked: Ei	Pages: 16	Page: 16

Procedure for installing or replacing the inductive proximity switch:

The following instructions apply to the proximity switch with 2 mm switching distance listed above.



Caution!

Please follow the described steps exactly in order to avoid damaging on the proximity switch.

- Install the inductive proximity switch only when the brake not stands under pressure.
- Screw the inductive proximity sensor into the brake caliper housing until the gap between the inductive proximity sensor and the back side of the brake pad is approx. 1.5 mm.
- Secure this position with counter nuts.
- Connect the inductive proximity switch on. The LED on the proximity switch must now glow.
- Test for proper function by activating the brake saddle several times in succession.