

# Airflex® DBBS Component Parts

## Section E

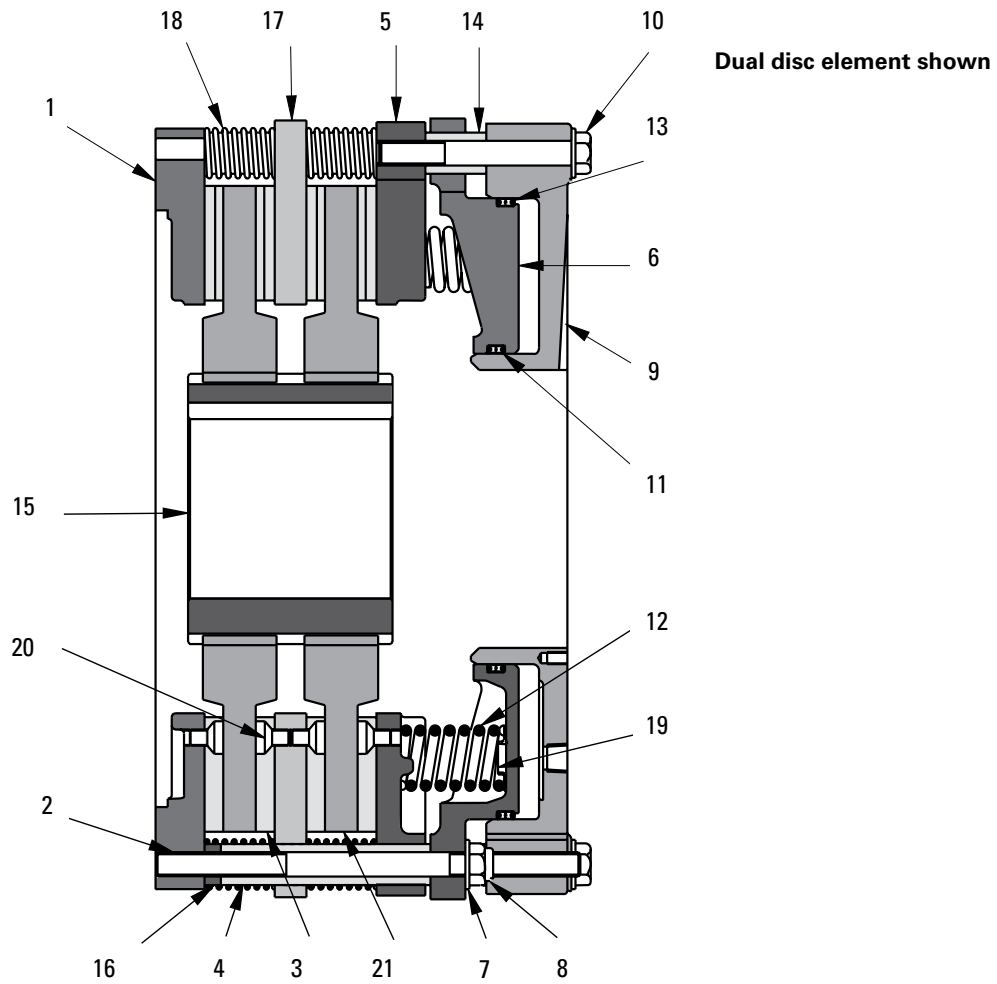

Item Number	Description
1	Mounting Flange
2	Stud
3	Friction Disc
4	Clamp Tube
5	Pressure Plate
6	Spring Housing
7	Flat Washer
8	Lock Nut
9	Cylinder
10	Hex Head Screw
11	Inner Seal
12	Spring
13	Outer Seal
14	Spacer Tube
15	Gear
16	Wear Spacer
17	Reaction Plate
18	Release Spring
19	Spring Retainer
20	Flat Head Screw
21	Disc

# Airflex® DBBS Brake Elements

## Section E

### Dimensional and Technical Data

English	Dimensions in inches			
120DBBS	3.50	5.63	10.30	3.00
220DBBS	4.25	5.69	13.48	6.27
320DBBS	4.88	5.75	16.63	10.31
420DBBS	5.13	5.81	19.81	12.50
125DBBS	4.50	7.00	11.49	3.50
225DBBS	5.50	7.13	14.73	7.00
325DBBS	6.13	7.38	17.96	12.00
425DBBS	6.63	7.31	21.19	15.00
138DBBS	8.50	10.06	15.20	5.00
238DBBS	8.50	10.06	18.97	9.00
338DBBS	9.63	10.06	22.60	13.00
438DBBS	10.38	10.38	26.34	18.00

Size	Bore Range		D	D <sub>1</sub>
	Min.	Max.		
120DBBS	89	143	262	76
220DBBS	103	145	342	159
320DBBS	124	146	422	262
420DBBS	130	148	503	318
125DBBS	114	177	292	89
225DBBS	140	181	374	178
325DBBS	156	187	456	381
425DBBS	168	186	538	381
138DBBS	216	256	386	127
238DBBS	216	256	482	229
338DBBS	245	256	574	330
438DBBS	264	264	669	457
150DBBS	260	394	519	146
250DBBS	314	394	631	254
350DBBS	353	394	744	368
450DBBS	378	394	895	508

#### SI Dimensions in millimeters

English	Dimensions in inches							
20DBBS	1.50	0.38	1.00	8.50	23.250	18.250	23.82	1/2-14
25DBBS	1.75	0.25	1.00	11.50	30.630	24.375	30.89	1/2-14
38DBBS	2.45	0.25	1.00	16.50	44.750	36.375	45.00	3/4-14
50DBBS	3.50	0.25	2.00	23.00	46.250	57.64	1-11	1/2

Size	D <sub>31</sub>	D <sub>44</sub>	D <sub>45</sub>	H <sub>16</sub>	J <sup>⊕</sup>	J <sub>1</sub> <sup>⊕</sup>	J <sub>2</sub> <sup>⊕</sup>	O <sub>2</sub> <sup>⊕</sup>
20DBBS	38	10	25	216	590.6	463.5	605	1/2-14
25DBBS	44	6	25	292	778.0	619.1	785	1/2-14
38DBBS	62	6	25	419	1135.7	923.9	1143	3/4-14

#### SI Dimensions in millimeters

#### Notes:

- ① Brake in disengaged position.
- ② Tolerance +0.000/-0.003 in (+0,00/-0,08 mm)
- ③ Tolerance +0.003/-0.000 in (+0,08/-0,00 mm)
- ④ Maximum diameter of "as cast" surfaces.
- ⑤ American National Pipe Thread.

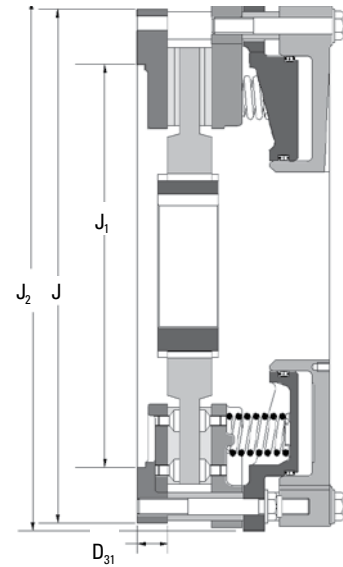

Single Disc element

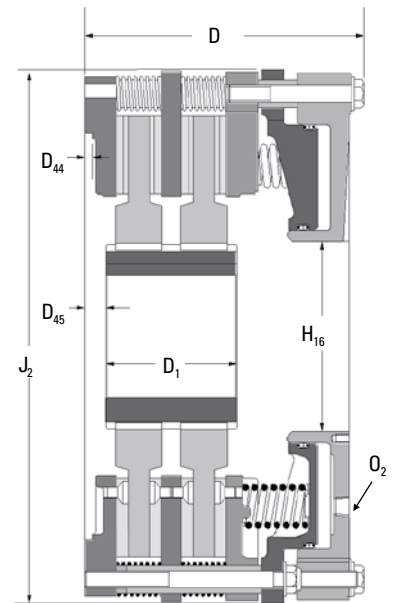

Dual Disc element

#### Mounting Bolt Circles

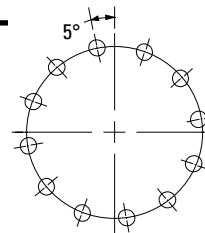

**20DBBS**  
(12) 0.656 (16,7) Ø  
Mounting holes equally spaced as shown on 22.000 (558.0) Bolt

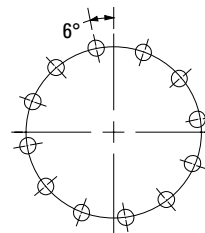

**25DBBS**  
(12) 0.656 (16,7) Ø  
Mounting holes equally spaced as shown on 28.750 (730,0) Bolt

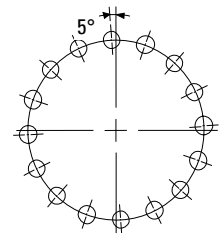

**38DBBS**  
(16) 1.062 (27,0) Ø  
Mounting holes equally spaced as shown on 42.000 (1066.8) Bolt

# Airflex® DBBS Brake Elements

## Section E

### Dimensional and Technical Data

English			lb-in	psi	in <sup>3</sup>	in <sup>2</sup>	lb-ft <sup>2</sup>	lb	rpm	
120DBBS	146323	415900	80,000	90	133	346	33	125	400	2200
220DBBS	146322	416059	150,000	90	133	692	65	232	550	2200
320DBBS	146373	416471	224,000	90	133	1,038	120	357	720	2200
420DBBS	146374	416472	220,000	90	133	1,384	159	464	914	2200
125DBBS	146320	416073	173,000	90	259	628	89	212	880	1700
225DBBS	146330	416074	325,000	90	259	1,255	178	416	1,318	1700
325DBBS	146382	416477	455,000	90	259	1,883	309	682	1,585	1700
425DBBS	146383	416470	585,000	90	259	2,510	411	854	1,882	1700
138DBBS	146328	416068	630,000	90	612	1,357	553	583	2,125	950
238DBBS	146329	416069	1,200,000	90	612	2,714	1,094	1,100	3,125	950
338DBBS	146384	416414	1,730,000	90	612	4,071	1,709	1,680	4,085	950
438DBBS	146385	416461	2,200,000	90	612	54,28	2,285	2,264	4,975	950
150DBBS	146524	417277	1,798,000	120	1,115	2,111	1,682	1,071	5,872	600
250DBBS	146525	417278	3,284,000	120	1,115	4,222	3,330	1,929	7,196	600
350DBBS	146526	417279	4,555,000	120	1,115	6,333	4,895	2,738	8,685	600
450DBBS	146527	417280	5,578,000	120	1,115	8,444	6,506	3,515	10,092	600

Size ⑥	Part Number ①	Gear Part Number	M <sub>0</sub> ② Torque Rating	Minimum Releasing Pressure ④	Releasing volume ⑤	Friction Area	Disc & Gear	Housing	Maximum Speed	
							Wk <sup>2</sup> J	Weight Mass		
120DBBS	146323	415900	9.032	6,2	2,18	2.232	1,39	56	181	2200
220DBBS	146322	416059	16.935	6,2	2,18	4.465	2,74	105	249	2200
320DBBS	146373	416471	25.290	6,2	2,18	6.697	5,06	162	327	2200
420DBBS	146374	416472	24.839	6,2	2,18	8.930	6,70	211	415	2200
125DBBS	146320	416073	19.532	6,2	4,24	4.052	3,75	96	398	1700
225DBBS	146330	416074	36.693	6,2	4,24	8.097	7,50	188	596	1700
325DBBS	146382	416477	51.372	6,2	4,24	12.149	13,03	310	720	1700
425DBBS	146383	416470	66.049	6,2	4,24	16.194	17,34	388	855	1700
138DBBS	146328	416068	71.127	6,2	10,02	8.755	23,30	264	962	950
238DBBS	146329	416069	135.480	6,2	10,02	17.510	46,10	498	1.414	950
338DBBS	146384	416414	195.325	6,2	10,02	26.265	72,10	736	1.856	950
438DBBS	146385	416461	248.391	6,2	10,02	35.020	96,41	1.029	2.261	950
150DBBS	146524	417277	203,164	8.3	18.3	13,619	70.88	486	2,663	600
250DBBS	146525	417278	371,073	8.3	18.3	27,239	140.33	875	3,264	600
350DBBS	146526	417279	514,689	8.3	18.3	40,858	206.28	1,242	3,939	600
450DBBS	146527	417280	630,282	8.3	18.3	54,477	274.16	1,594	4,578	600
SI			N·m	bar	dm <sup>3</sup>	cm <sup>2</sup>	kg·m <sup>2</sup>	kg	rpm	

#### Notes:

- ① Basic part number only. Does not include gear. Gear must be ordered separately with bore and keyway requirements.
- ② Dynamic torque shown. Static torque approximately 15% greater. Torque values are for new linings. Torque decreases with lining wear. At worn out condition, torque is approximately 0.66 of values shown.
- ③ Torque ratings are for units with a standard complement of springs. Consult factory for torque ratings of units with non-standard spring configurations.

- ④ Maximum allowable cylinder pressure is 120 psi (8,31 bar).
- ⑤ Absolute volume of releasing cavity.
- ⑥ Triple and quadruple disc units can also be supplied for each size. Consult factory for dimensional and technical data.