

ST 520 - 18

Electro-hydraulic Thrusters (ST)

Introduction

Electro-hydraulic thruster is a device which develops linear thrust (or force) required to operate the required mechanism. The input to the device is three phase supply. The thrusters are widely used to actuate Thruster shoe Brakes, commonly used in material handling machines. Thrusters in various models develop 15 kg to 295 kg. In stroke lengths of 51, 76 & 127 mm.

Rated Supply : 400/440V/50Hz/3 - Phase (Thrusters or other voltages (up to 600 V) on request.) Thrusters should be mounted with in $\pm 10^\circ$ from vertical. Working fluid - Transformer oil to BS 148.

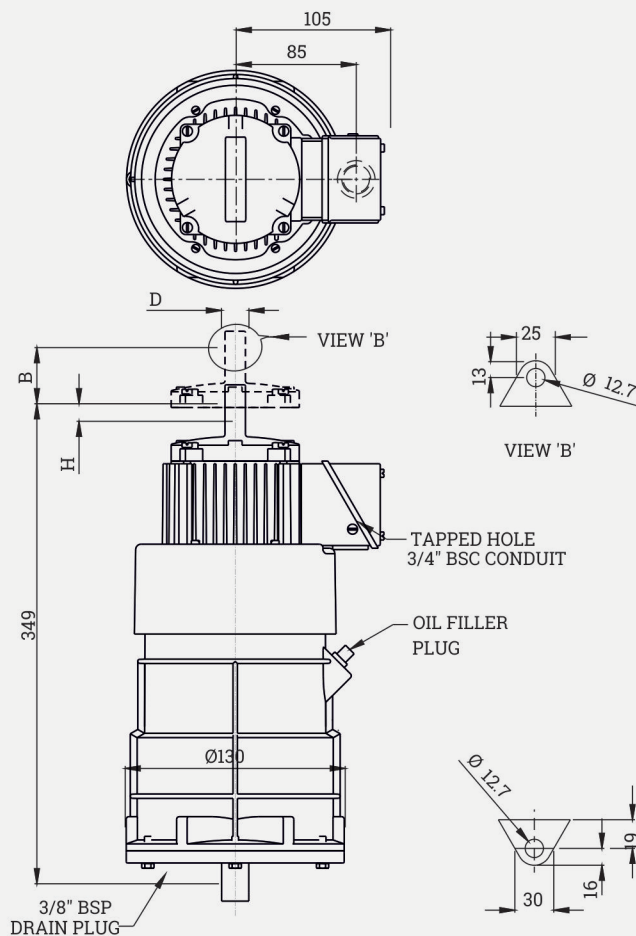

Thruster Model	Item Code	Thruster Details Lifting Force	Stroke	Supply Volts At 50 Hz	Oil Capacity	Wt.
		(kg)	(mm)	(V)	(Litres)	(kg)
ST - 520	100400011001	18	51	415	2	14

Supply Voltage 380/480/550/690V available on request



Speed-O-Controls Pvt. Ltd.

H. O. Unit - I : C-15/16, Nand Jyot Industrial Estate,
Andheri-Kurla Road, Mumbai - 400072,
Tel : (022) 42469700-30, 28518512-3-4,
Fax : (022) 42469797/ 28518516,
E-mail : sales@socgroup.in

Unit - II: Plot No. 4912, G. I. D. C., Phase IV,
Vatva, Ahmedabad - 382445
Tel.: (079) 40083201/2/3/4,
Fax : (079) 25841056,
E-mail : sales.amd@socgroup.in

Visit us at :
www.speedocontrols.com
www.socremote.com